

Optische Täuschungen

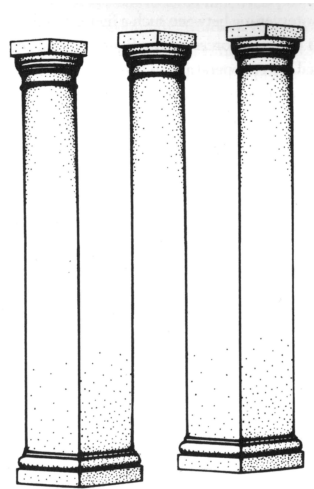

G. Zachmann

Clausthal University, Germany

cg.in.tu-clausthal.de



- Noch mehr aus dem neuen Buch von Ditzinger übernehmen!



Physiologische Effekte

- Hermann'sches Gitter:

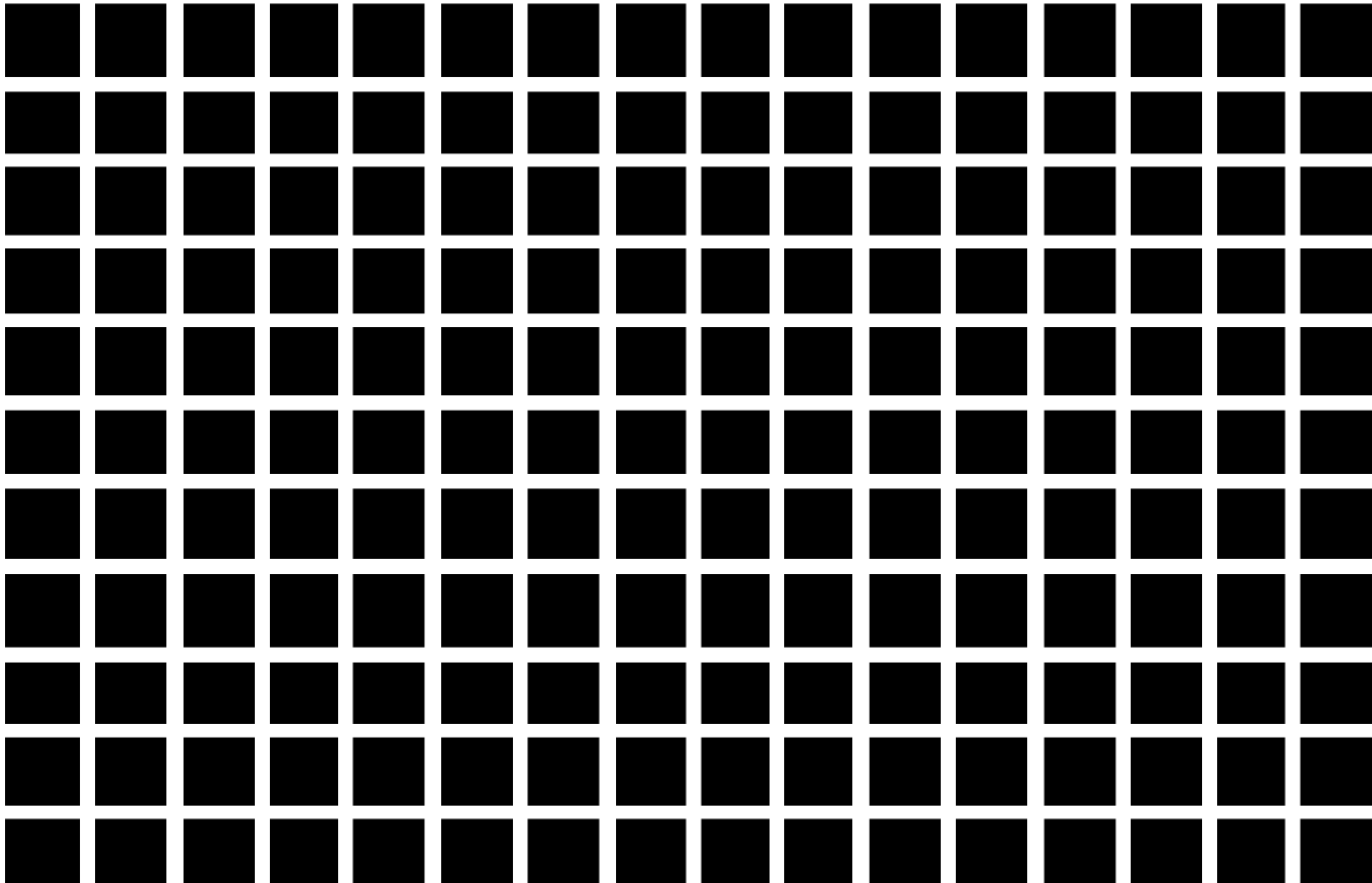



- Klassische Erklärung ist falsch
 - Laterale Inhibition /
Differenzenbildung / räumliche
Ableitung
- Beweis:
 - Der Effekt ist skalierungsinvariant
 - Tritt bei gekrümmten Linien nicht auf
 - Erst 2004 entdeckt! [ECVP 2004]
 - Tritt nicht bei gezackten Rändern auf

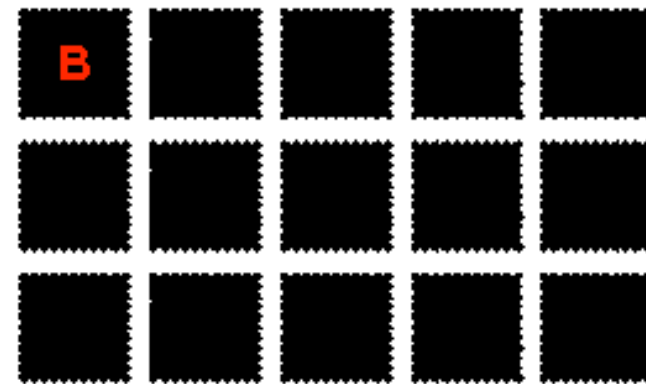
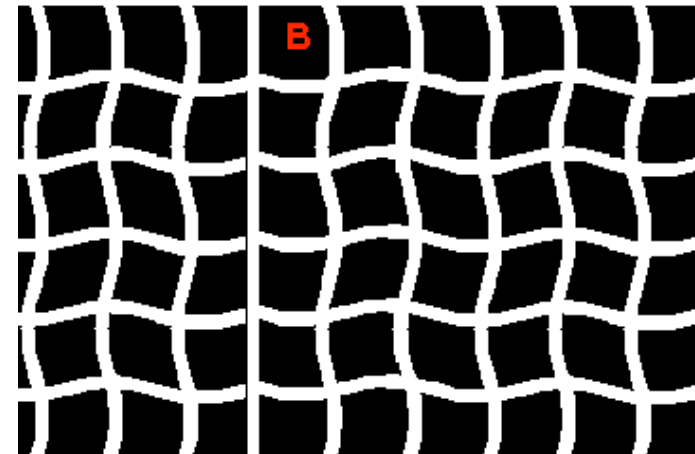
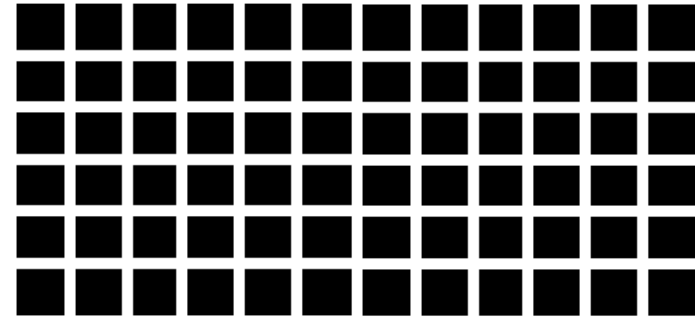



Variante: scintillating grid

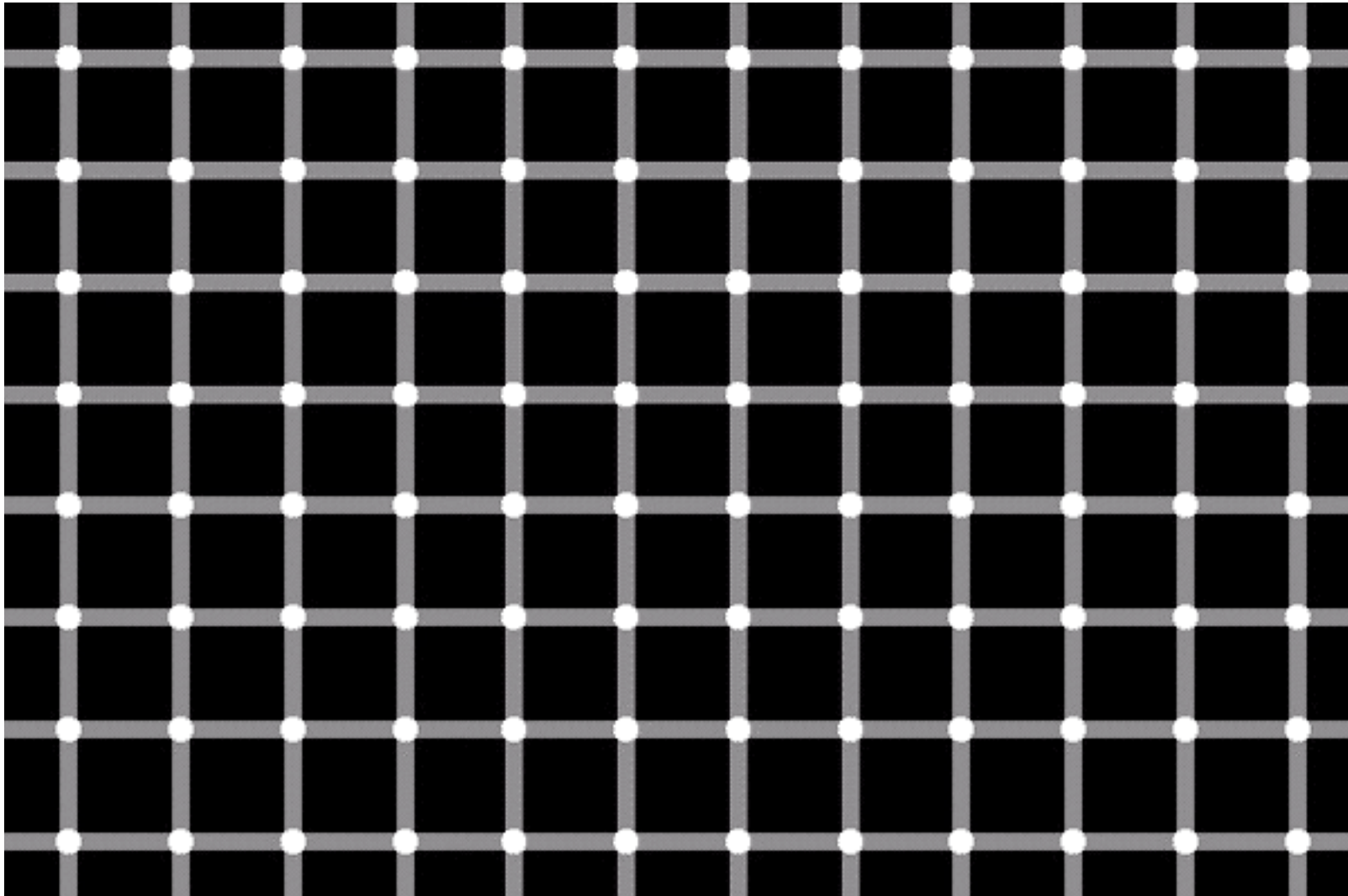



Mach-Bänder

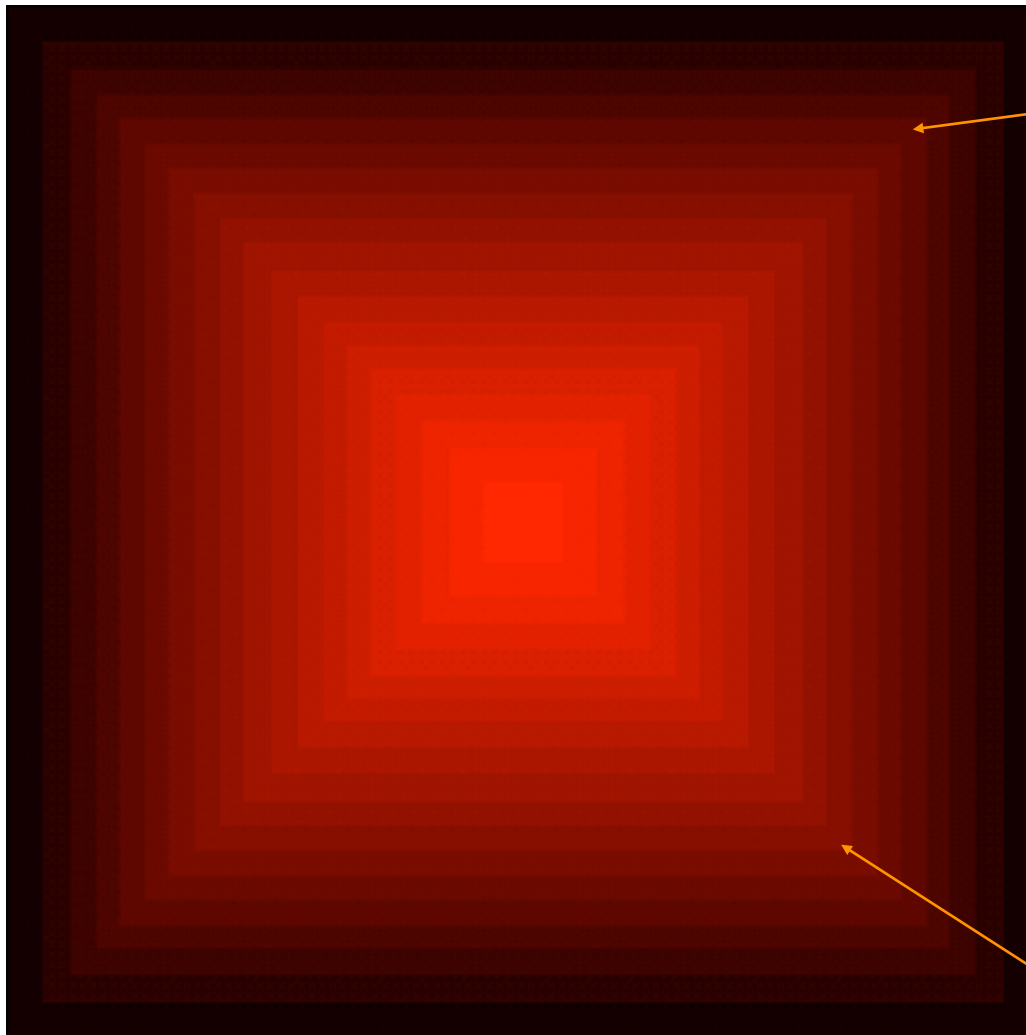

Die Intensität innerhalb eines Quadrates ist konstant!
Ein Farbverlauf von innen nach außen ist eine Illusion.

Die hellen Linien bei 45° (und 135°) sind eine Illusion!



Variante: Pyramiden-Effekt

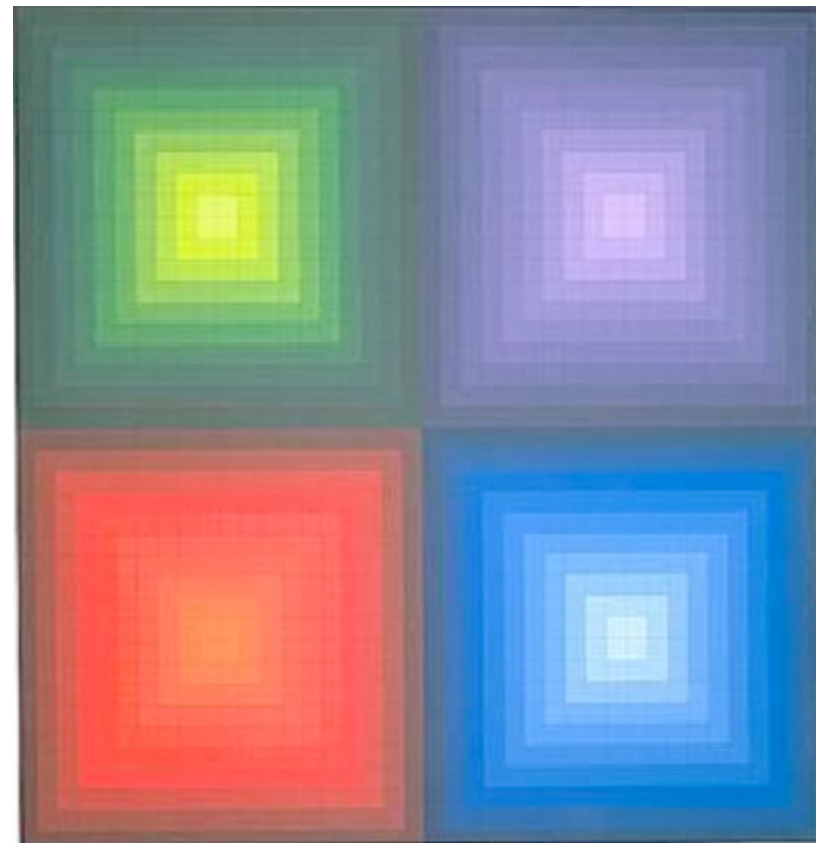
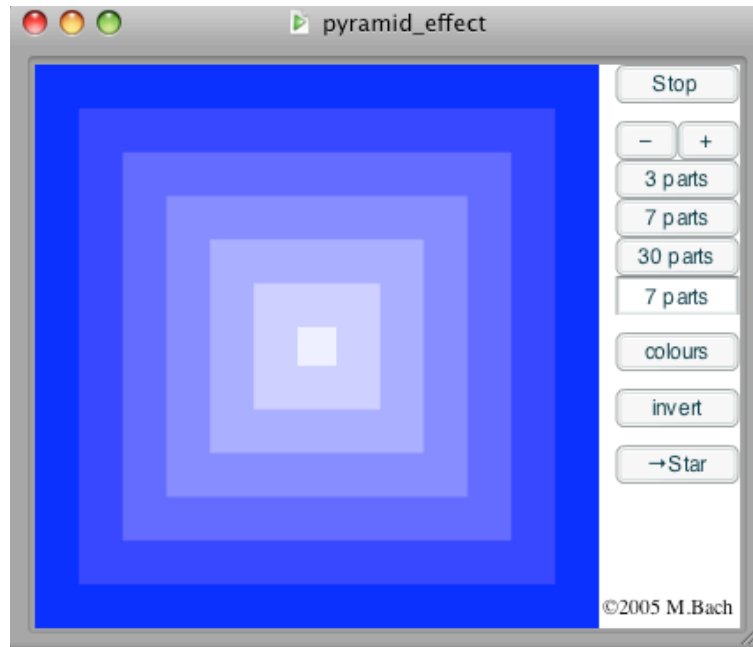

Victor Vasarely
Arcturus II
Öl auf Leinwand, 1966, 160.0 x 160 cm



- Die Cornsweet-Illusion:
 - Die Region rechts sieht ein klein wenig heller aus als die Region links
 - In Wahrheit gleich hell
 - Unterschied zu Mach-Bändern:
 - Gradient am mittleren Rand ist real, dieser erzeugt die Illusion
 - Hier betrifft der Effekt eine große Region

- Typische Erklärung (wahrsch. falsch):

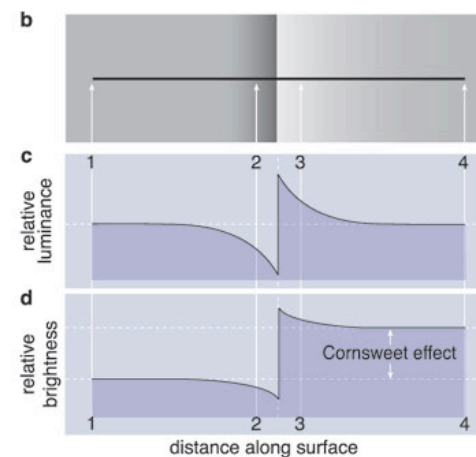



- Der Cornsweet-Effekt in einer realen Szene:

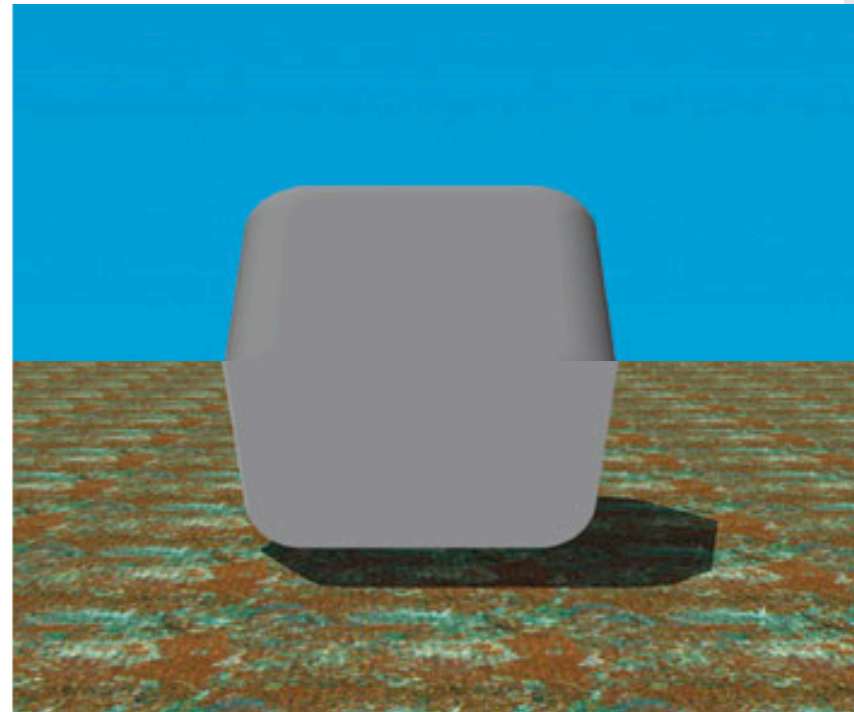
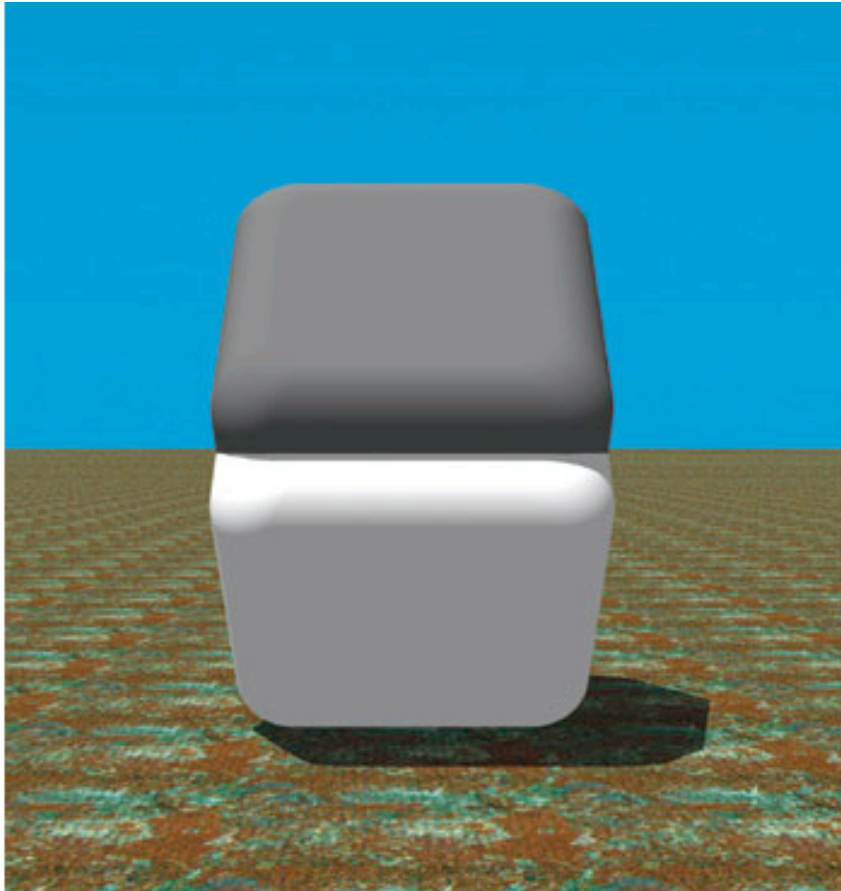



Beleuchtung

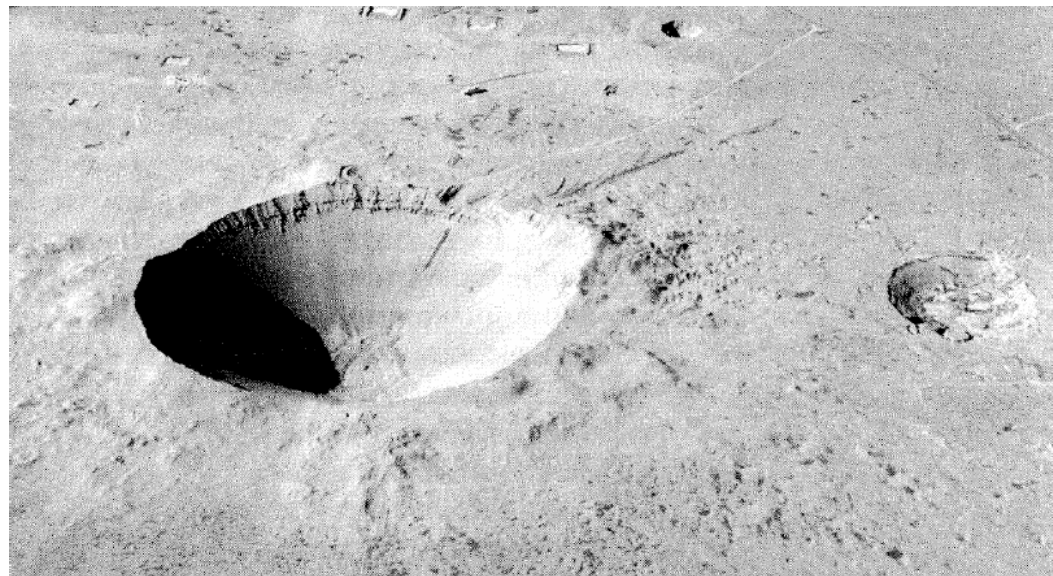
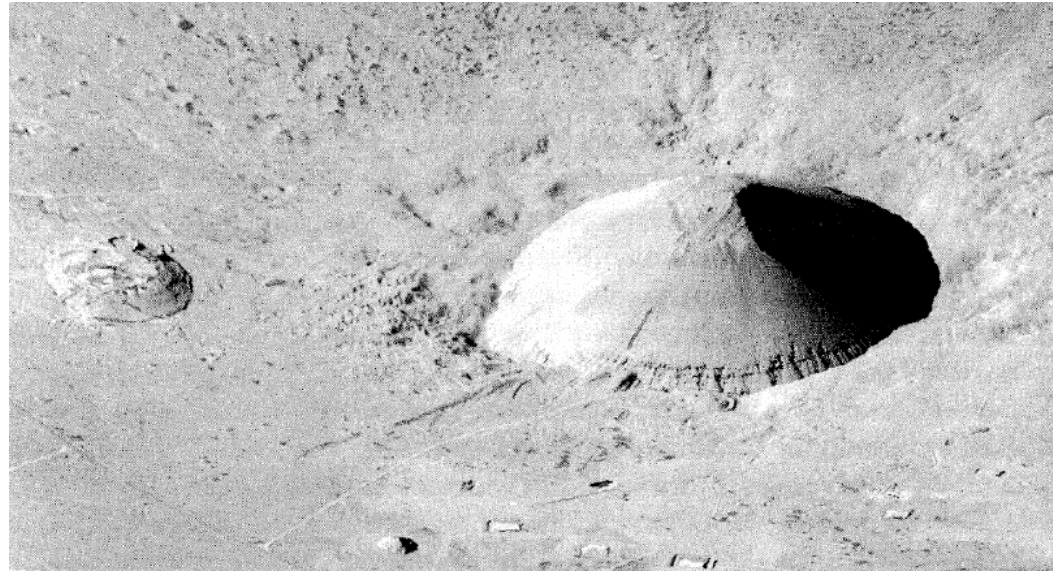



Contrast Adaptation

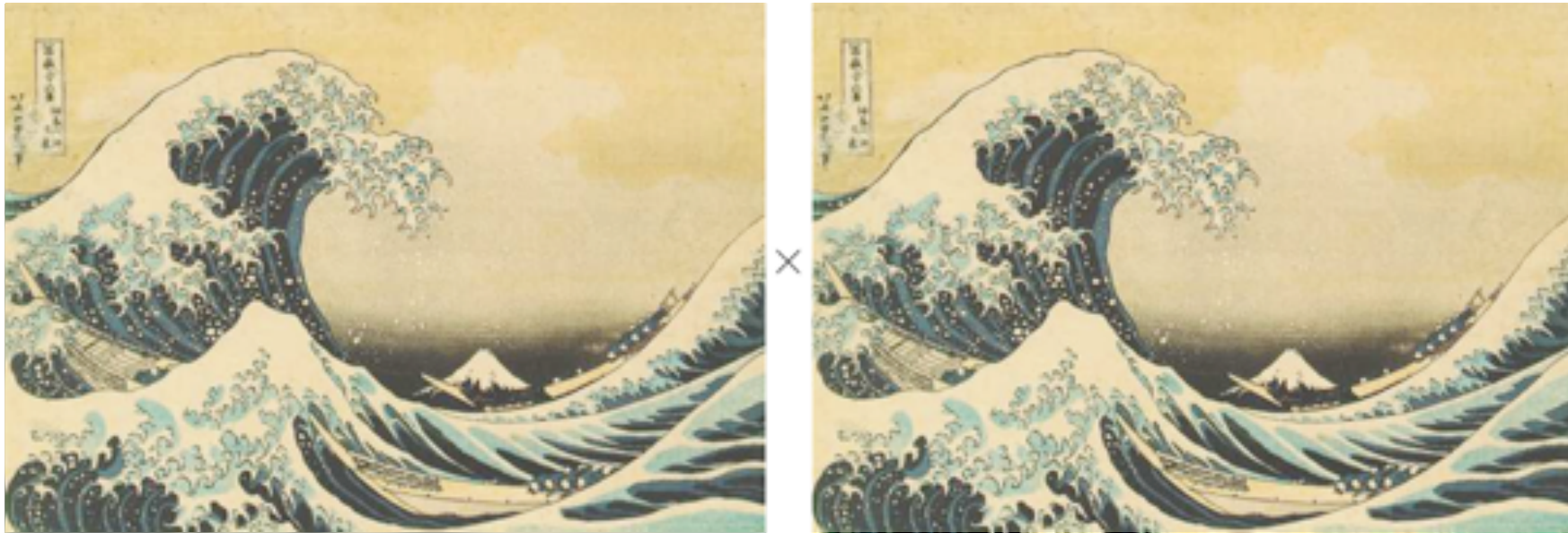

Katsushika Hokusai: “The Breaking Wave Off Kanagawa” (also called “The Great Wave”).
Woodblock print ($\approx 1831-1833$) from Hokusai’s series of 36 *Views of Mount Fuji*.



Simultankontrast

- Welches der beiden inneren Rechtecke ist heller?

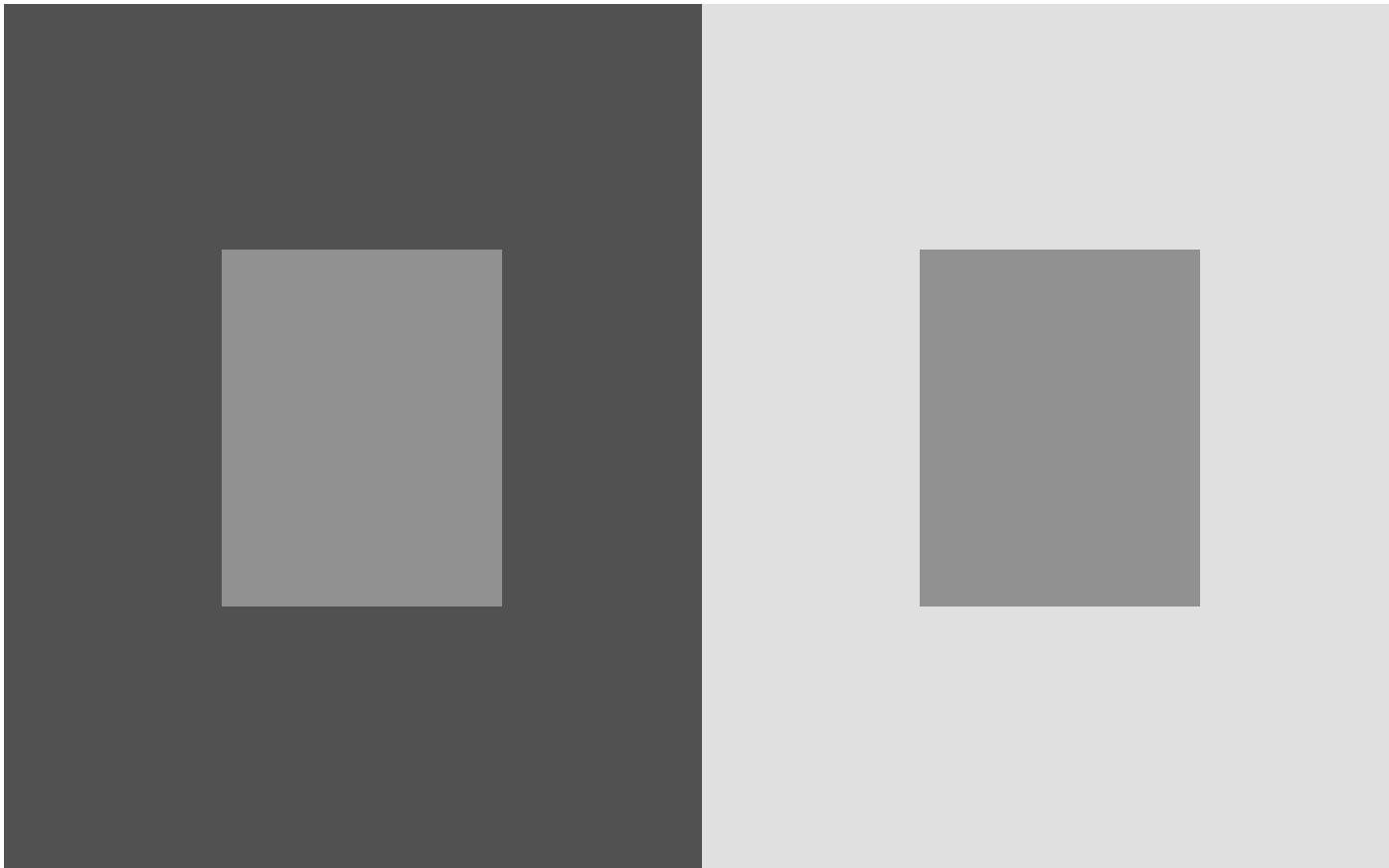



■ Reales Beispiel:

Checker-shadow illusion:
The squares marked A and B
are the same shade of gray.

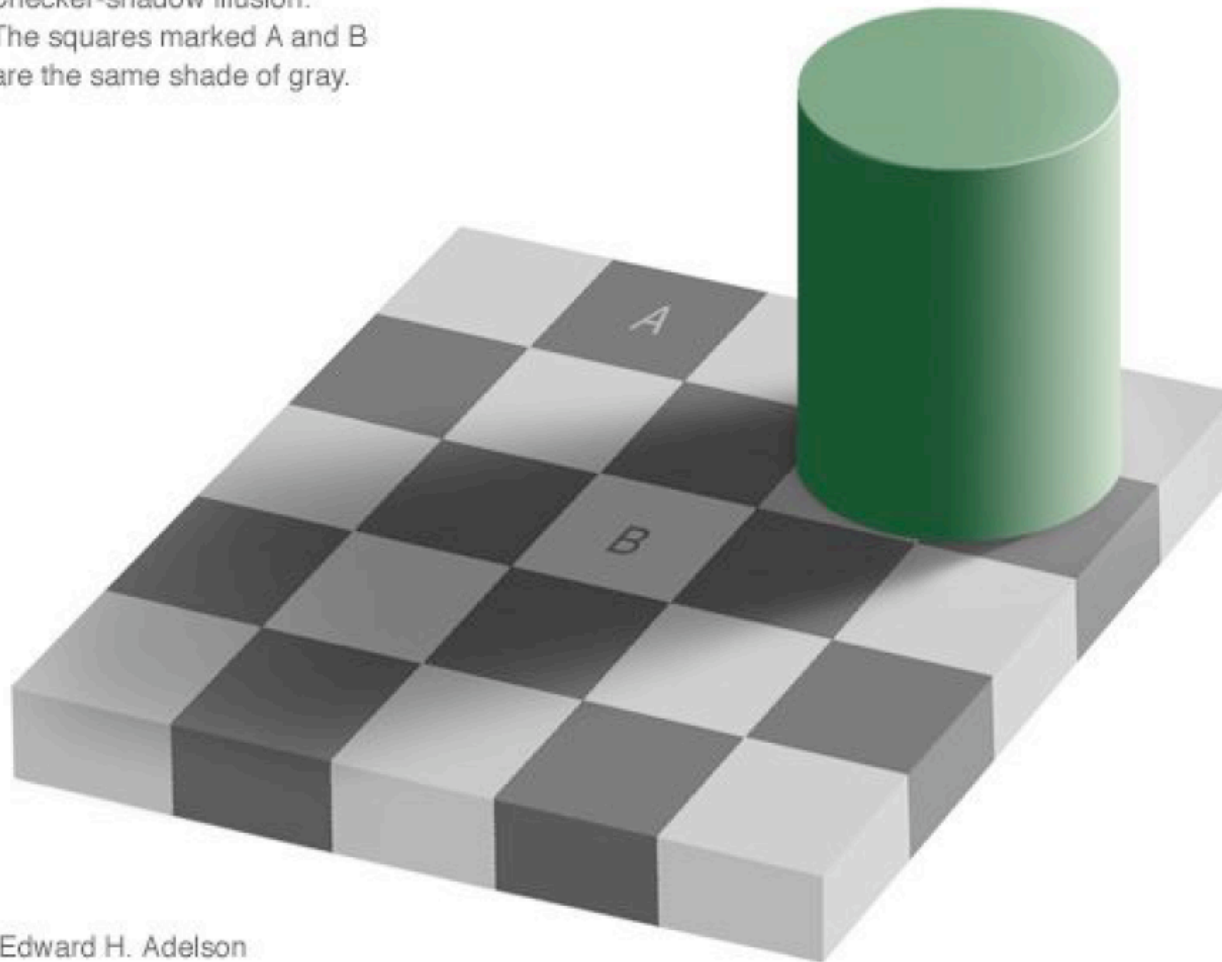

Edward H. Adelson



Simultaner Farbkontrast

- Das gibt es auch bei Farben:
- Das setzen Maler oft ein (oft auch ganz unbewußt):

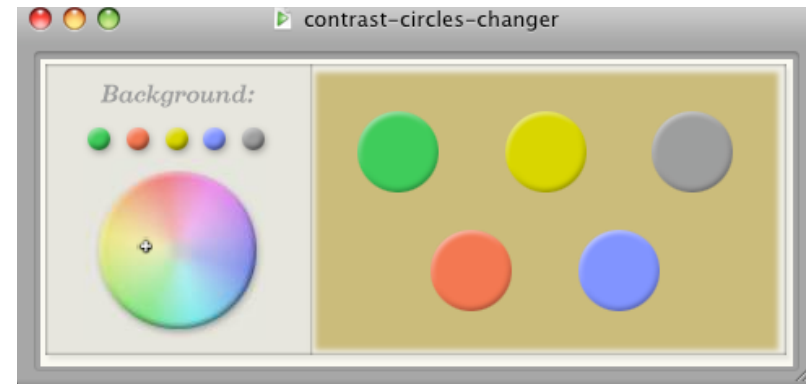



Hans Hofmann
Equinox
1958



Vincent van Gogh,
Cafe Terrace on the Place du Forum
September 1888



Ein (gemeines) Beispiel

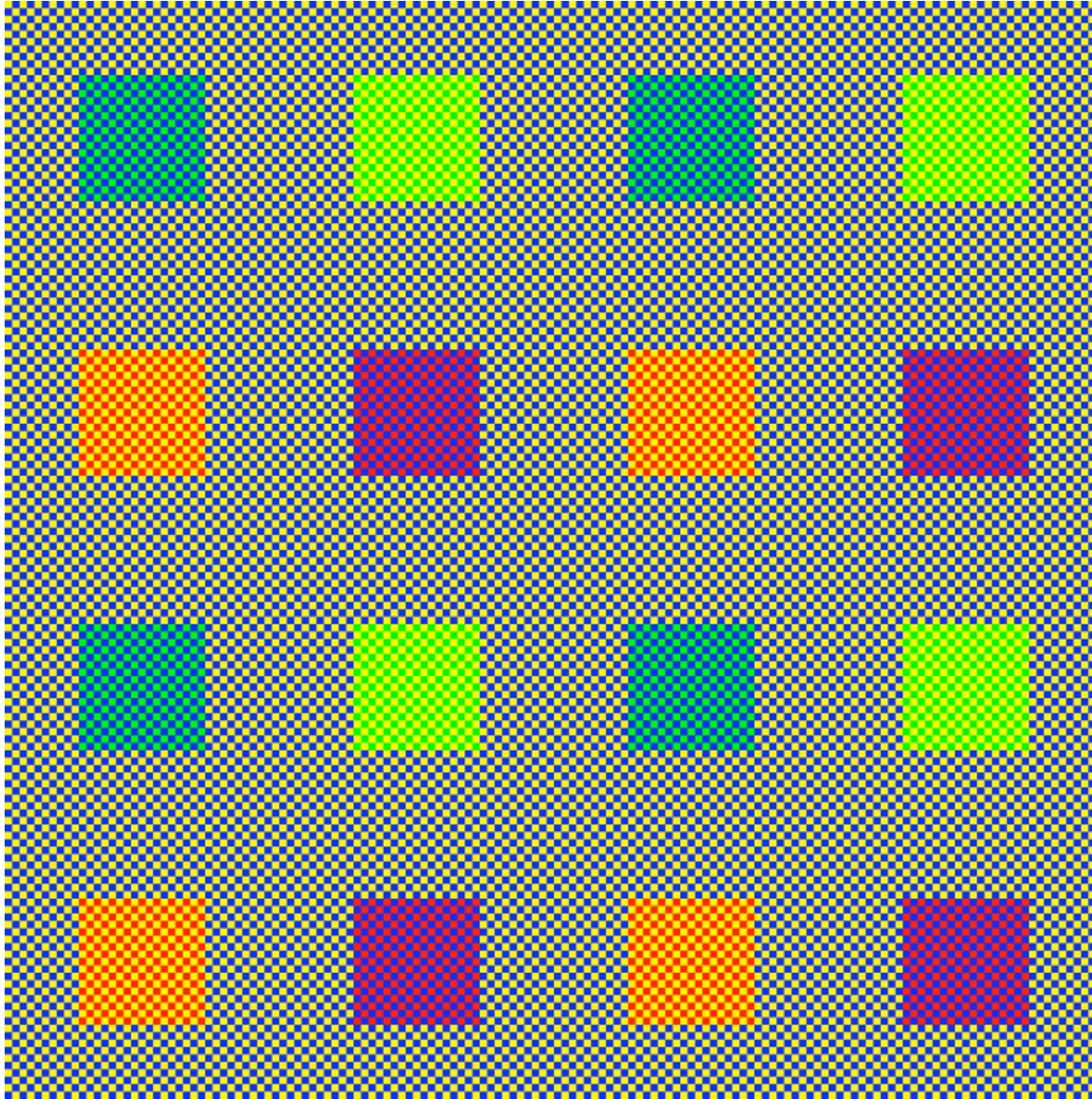

Wieviele verschiedene Farben haben die
4x4 halb verdeckten Quadrate?





- Zwei Ausschnitte aus der oberen Reihe:

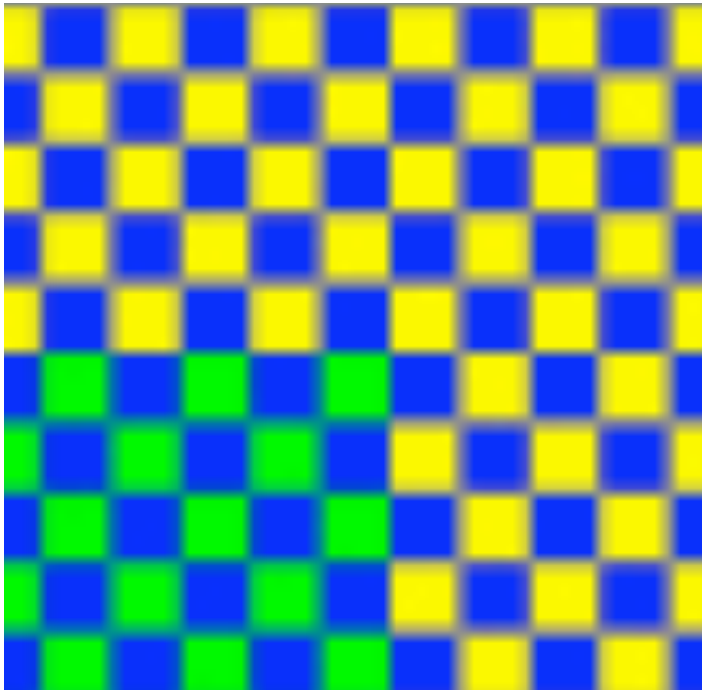



Variante: sukzessiver Kontrast

- Sie sehen zunächst 2 gleiche, gelbe Scheiben
- Danach 2 farbige Scheiben; fixieren Sie einen der beiden Mittelpunkte
- Danach schalten wir wieder um auf die beiden gelben Scheiben; halten Sie Ihre Augen fixiert auf den ausgesuchten Mittelpunkt

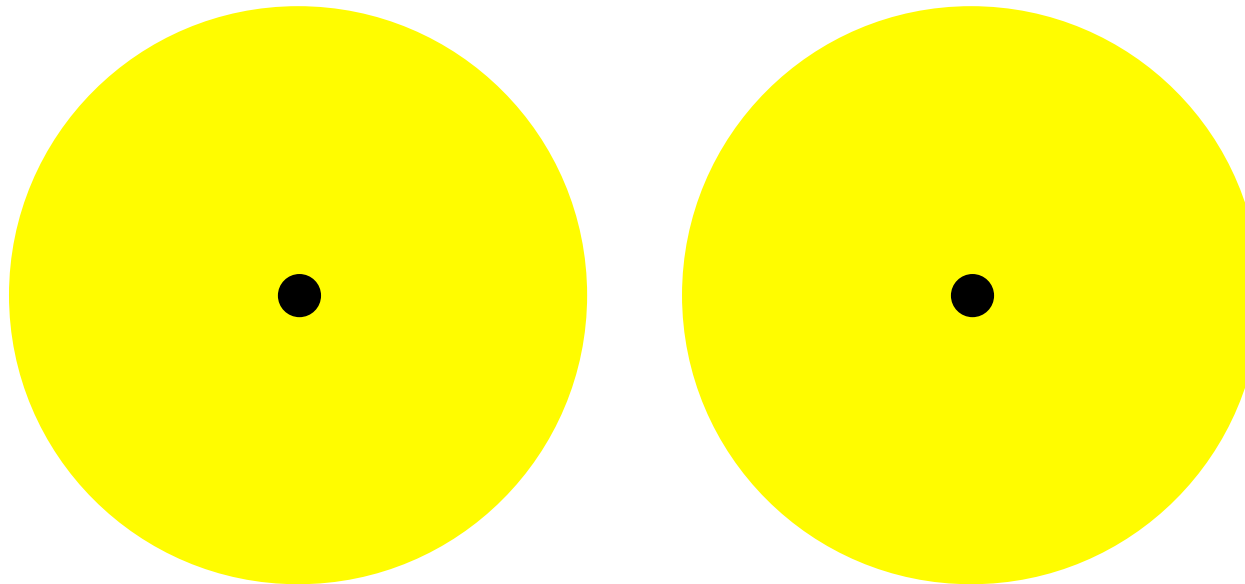

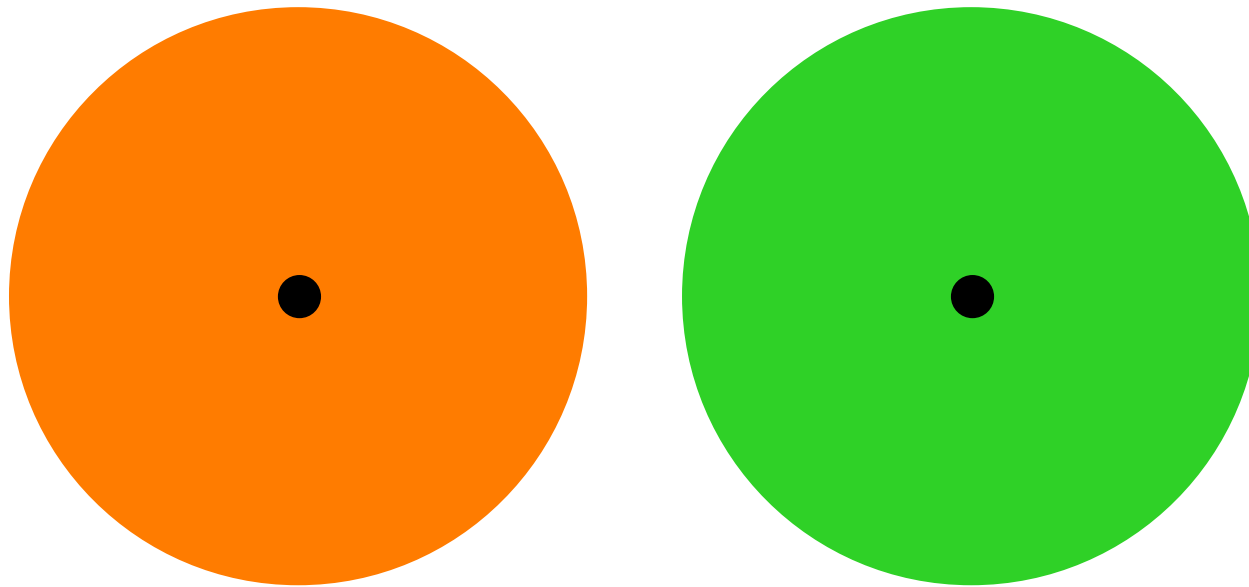

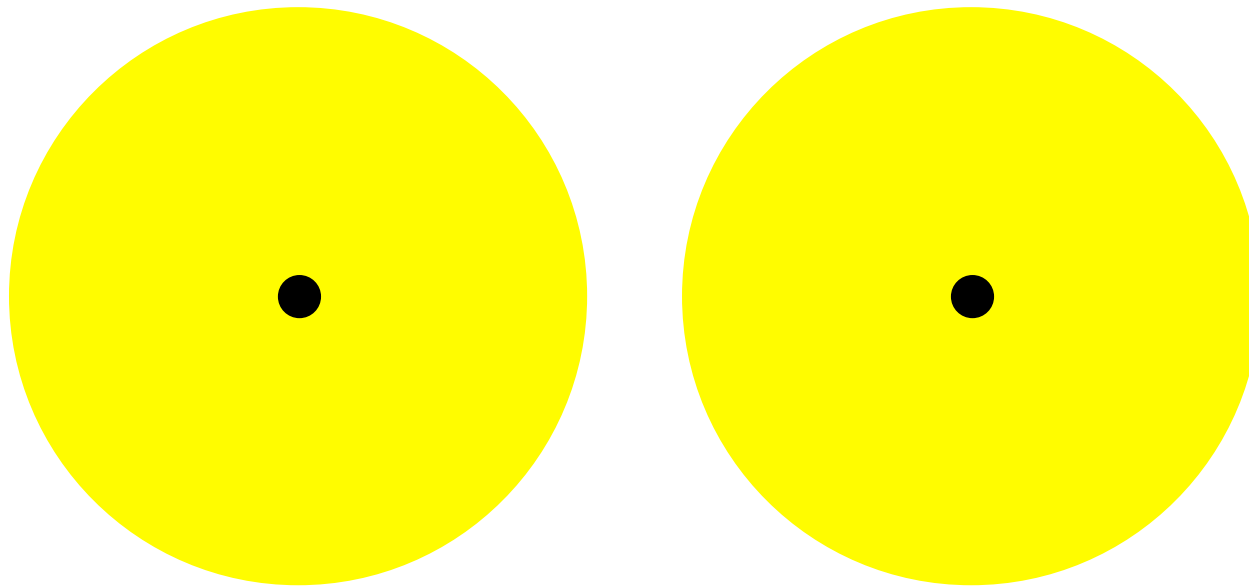



Nachbilder











The lilac chaser

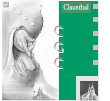
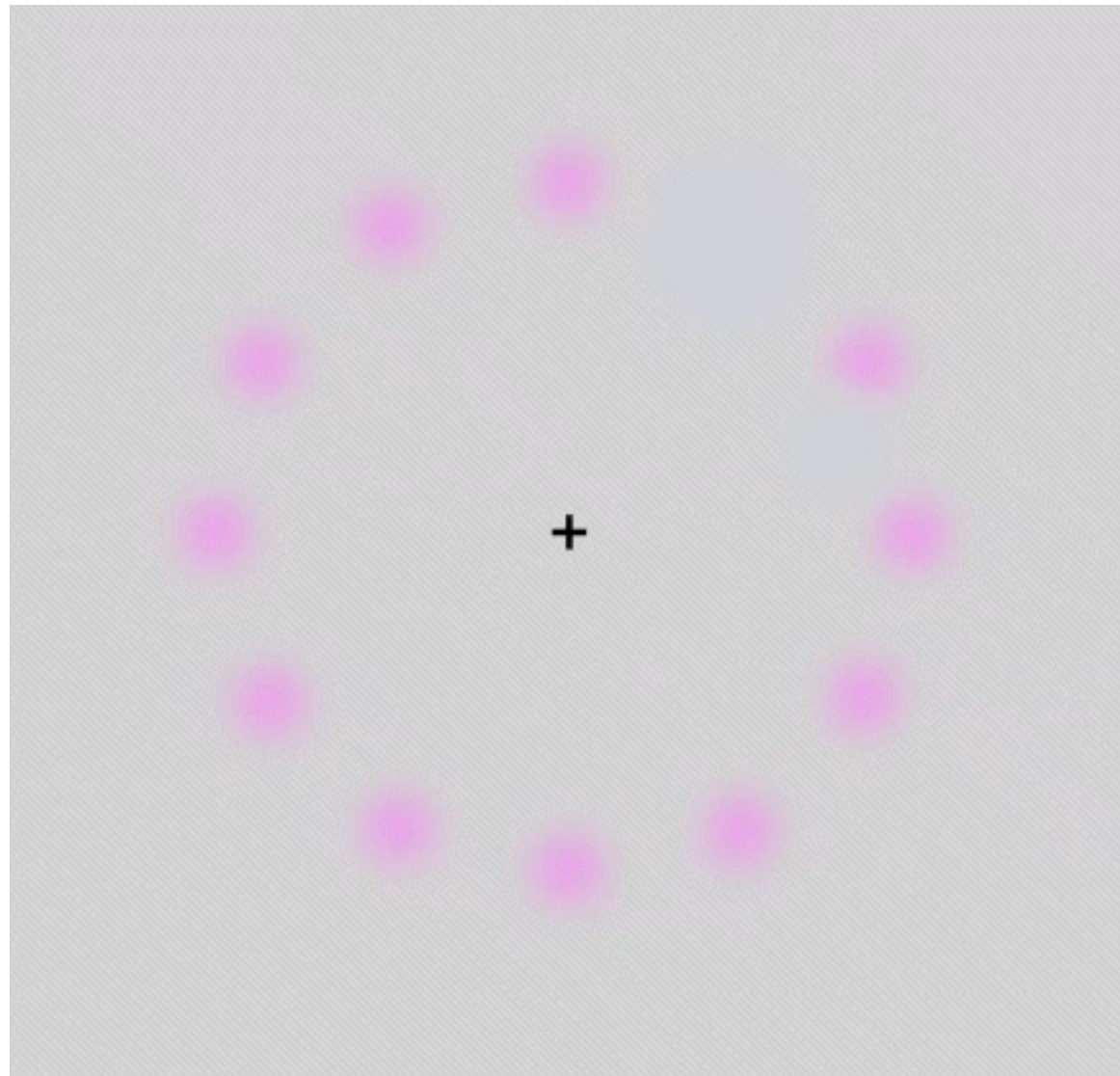



Der Hess-Effekt



Are the two pentagons aligned with each other?

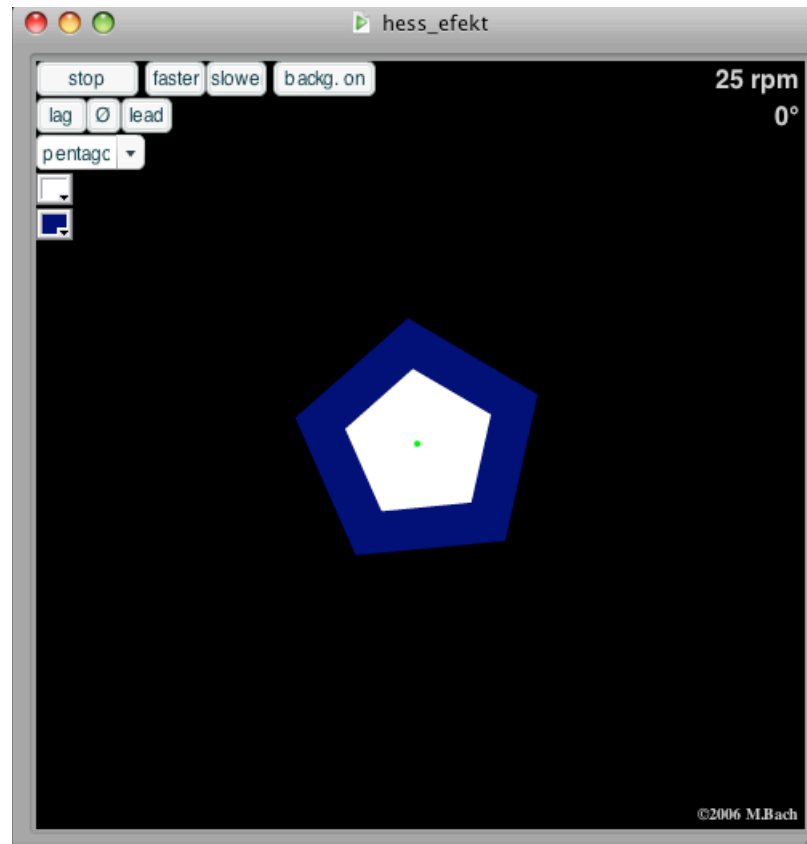



Benham's Kreisel

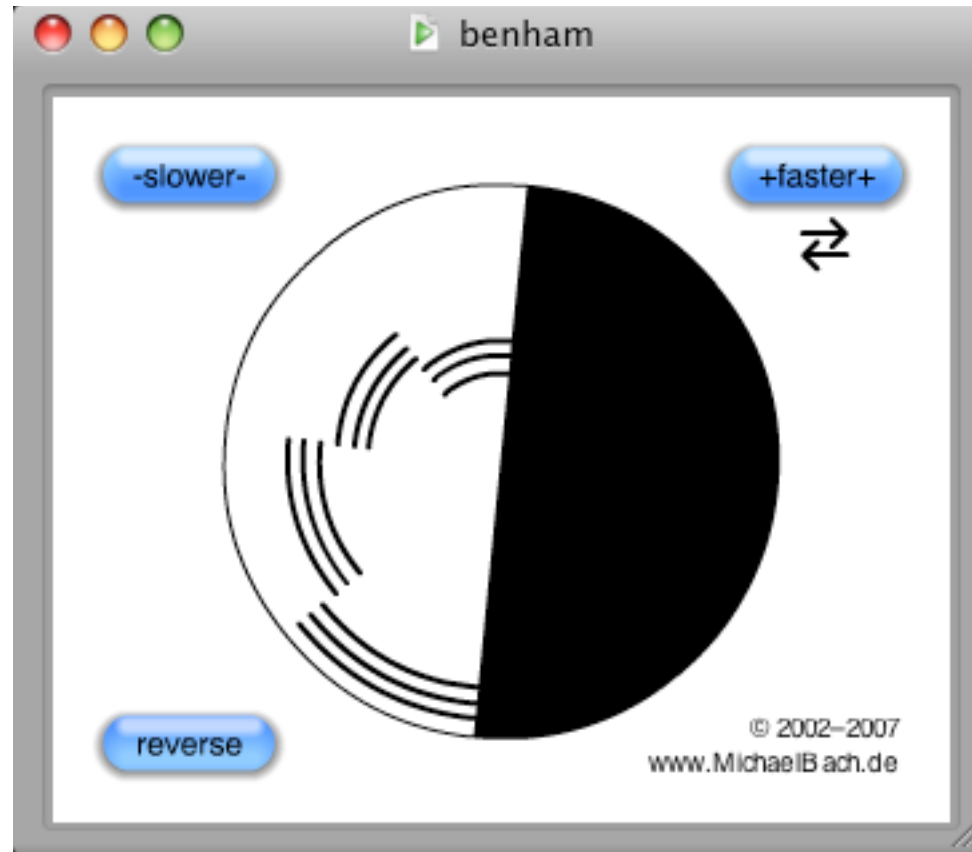



Ames Room



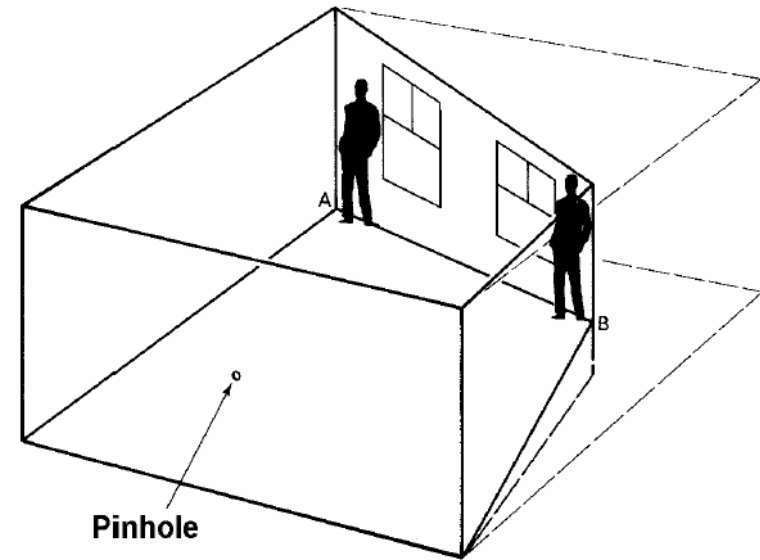
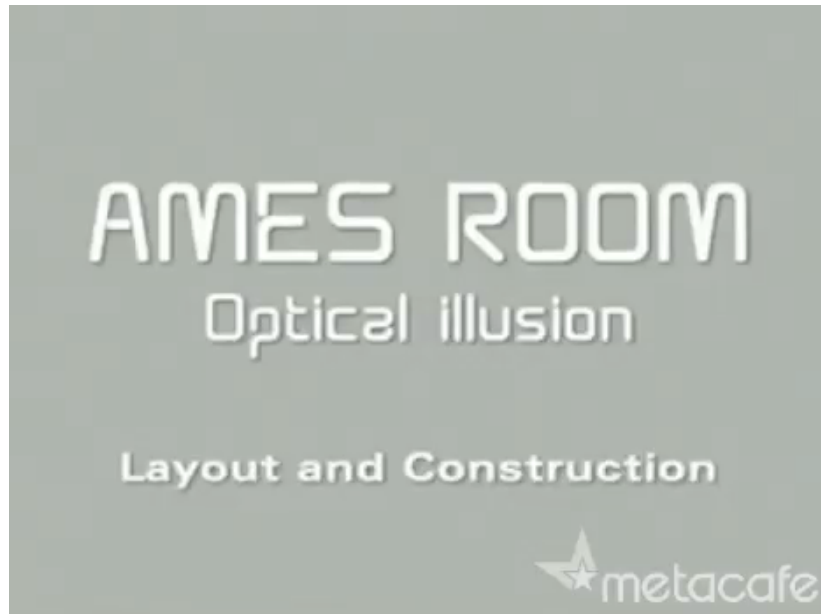



Unmöglicher Kasten



Jerry Andrus
[youtube.com]



Unmögliche Architektur von Escher

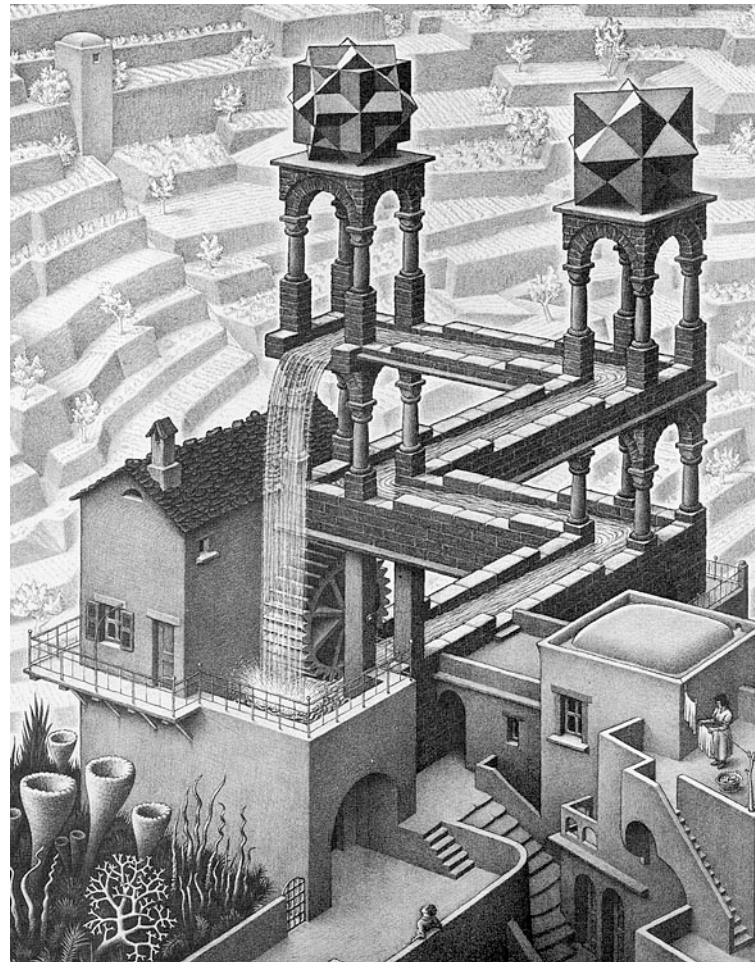



Movies inspired by Escher

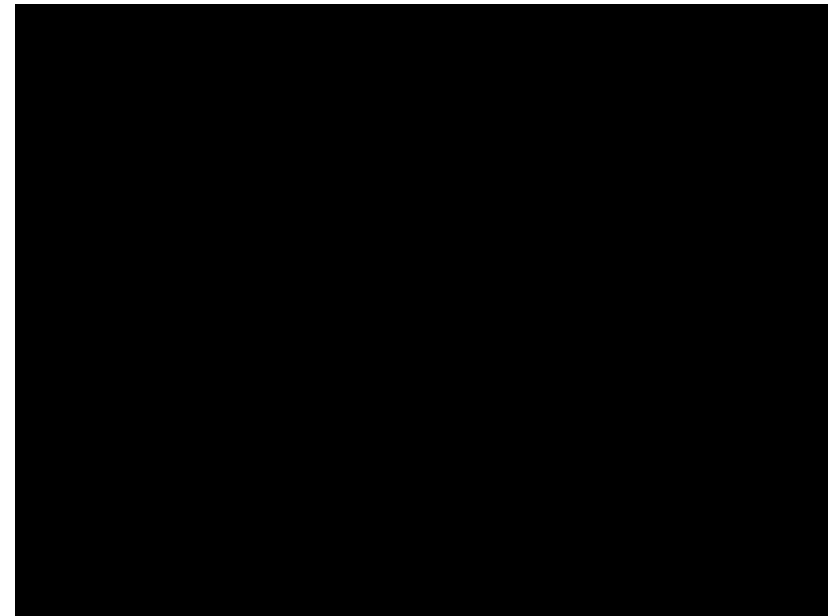
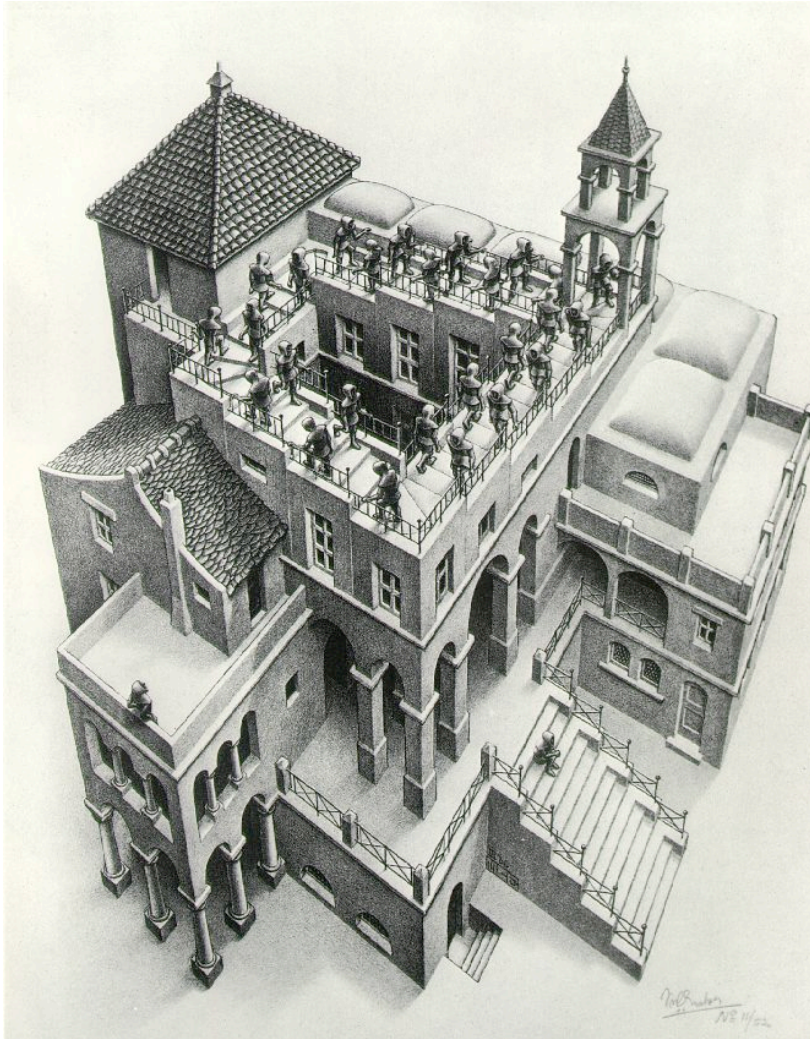

Goo-Shun Wang

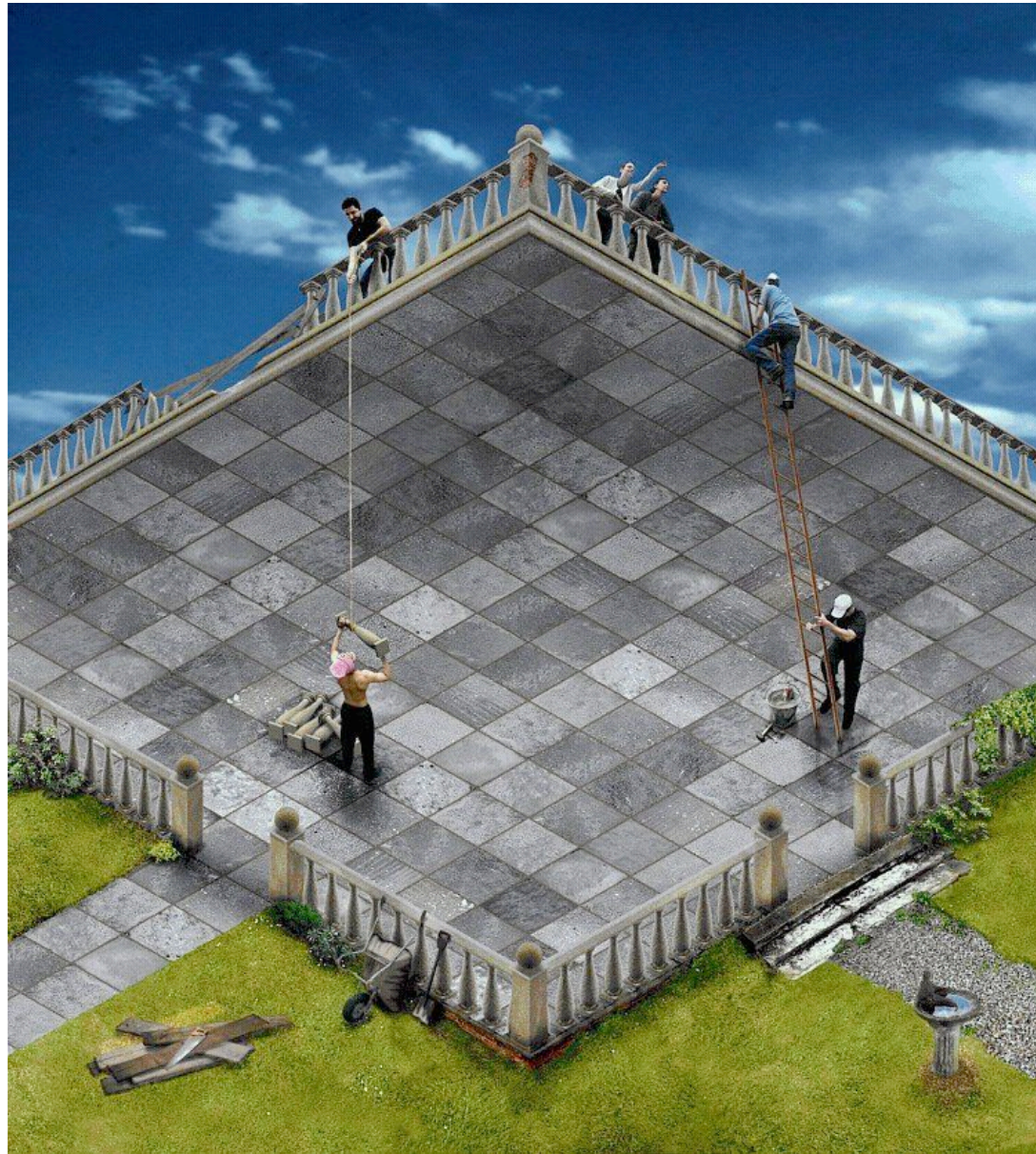

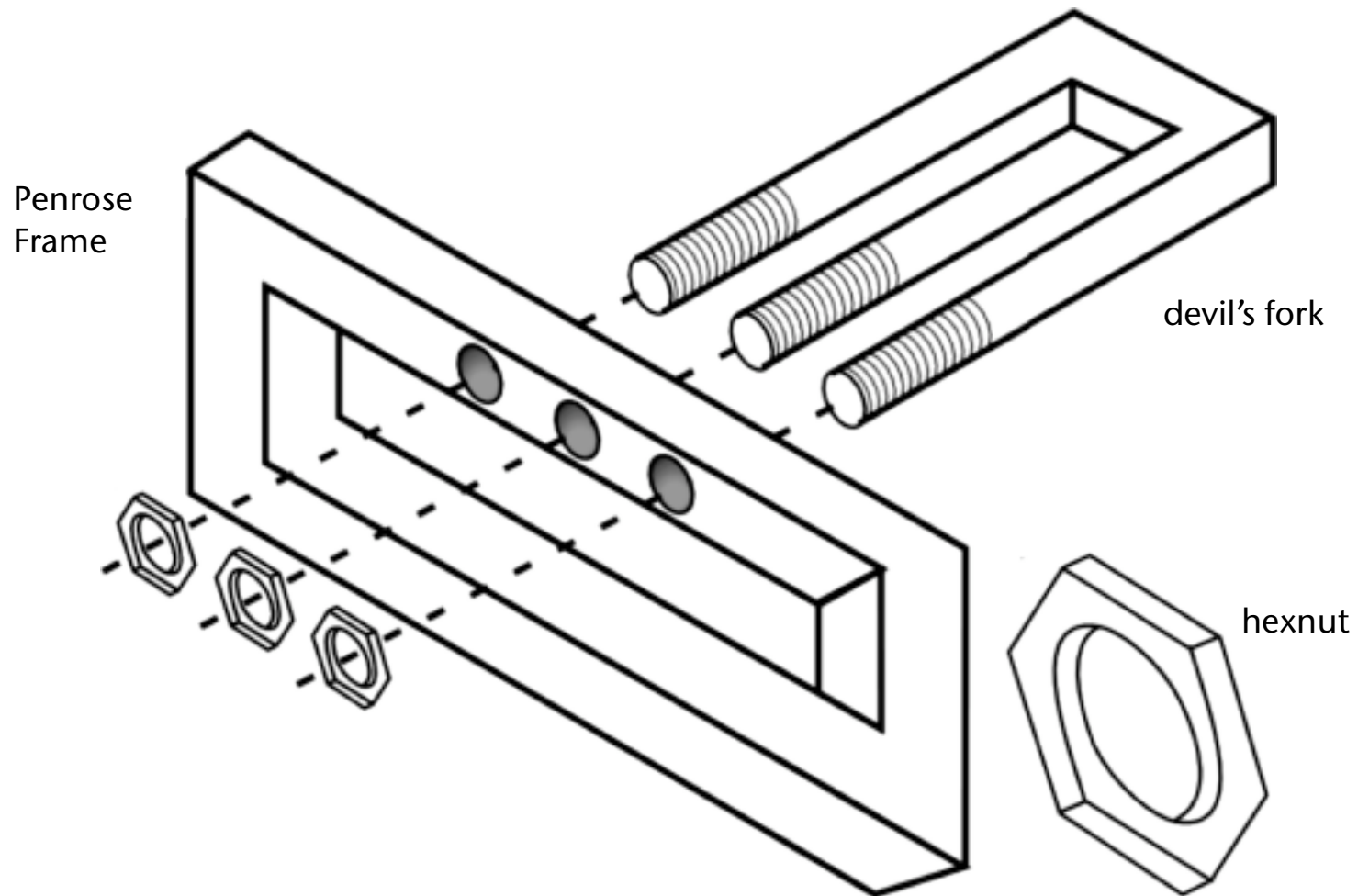

http://www.michaelbach.de/ot/cog_imposs1/index.html



Madonna and Child ~ Adoration of the Magi
From the Pericope of Henry II, ca. 1025



Kreidezeichnungen



Julian Beever



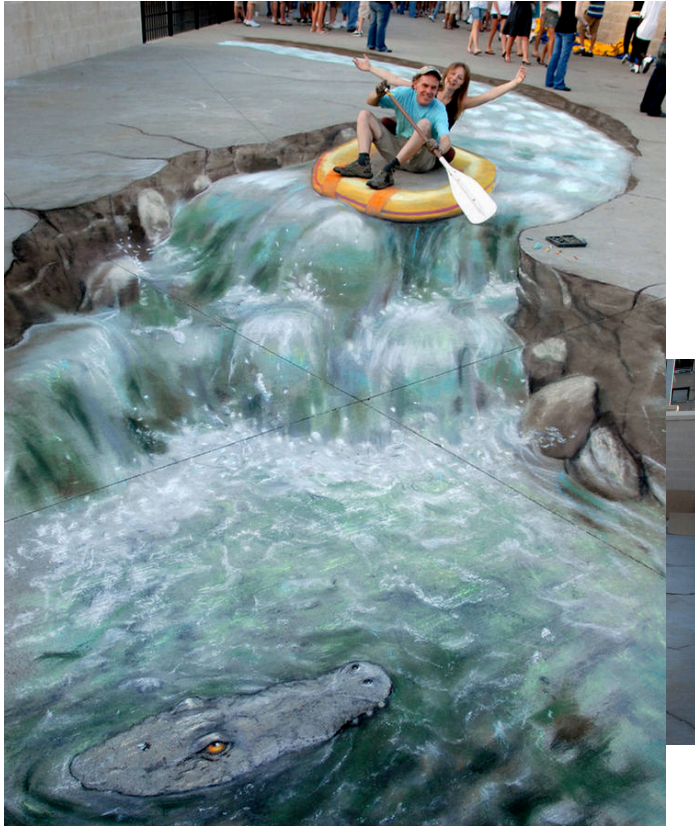

Julian Beever

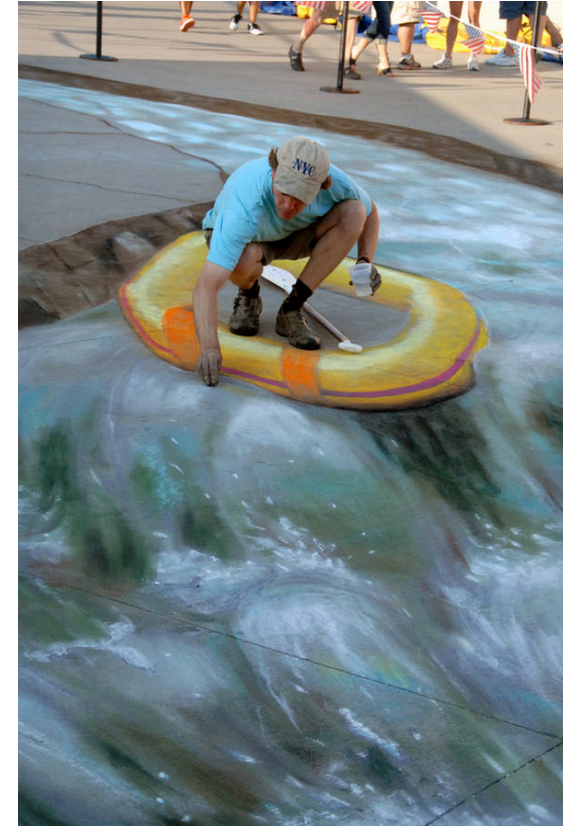



Felice Varini

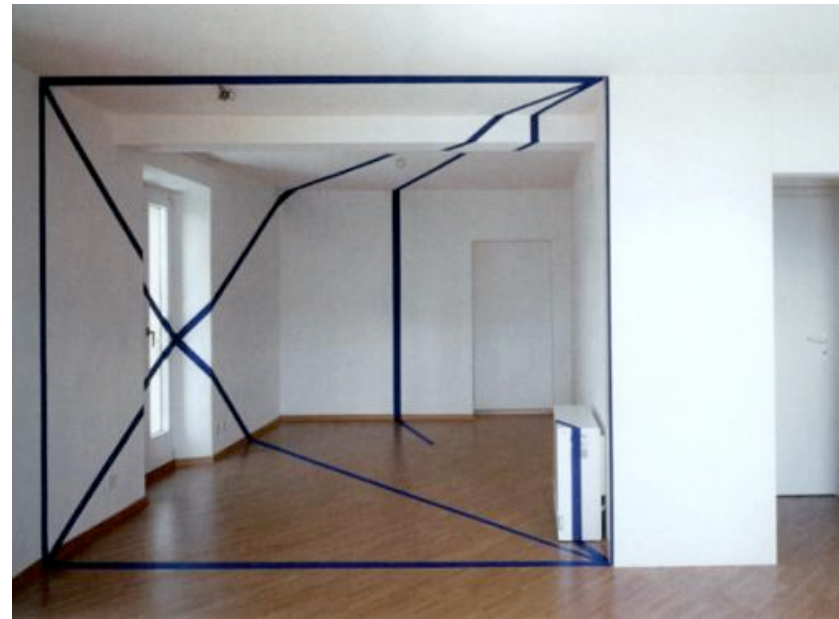
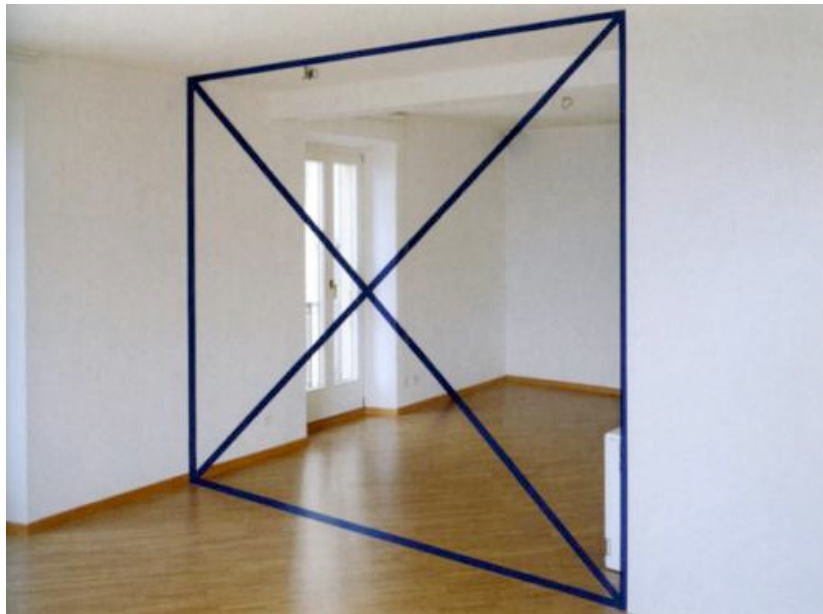





unknown



Größenverhältnisse



- Müller-Lyer Illusion (1889):

- Alle Liniensegmente sind gleich lang!

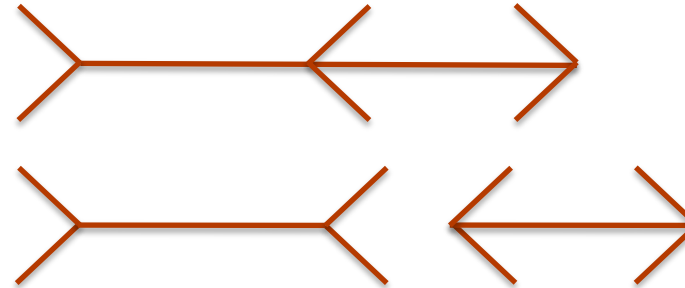

- Interaktive Variante:

http://www.michaelbach.de/ot/sze_muelue/index.html

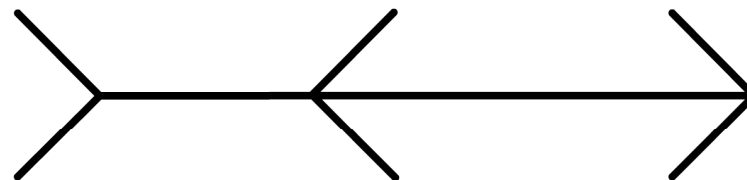

Show Ruler

©2002 www.michaelbach.de



- The Linear-Perspective Hypothesis:

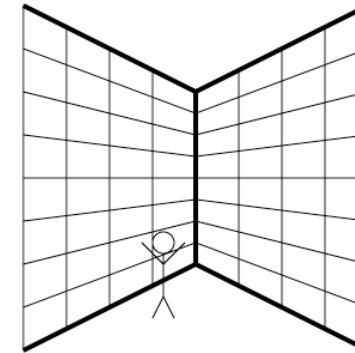
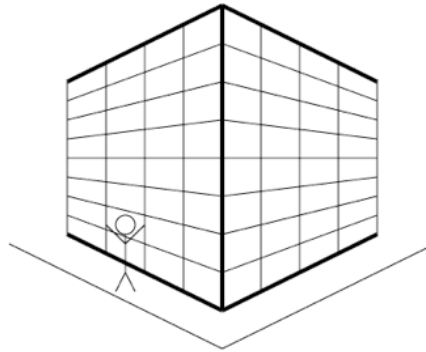

- Ponzo Illusion:

- Welche horizontale Linie erscheint länger?
- Erklärung:

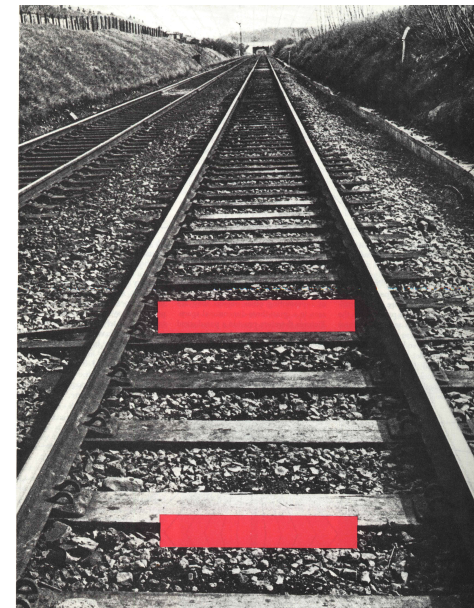
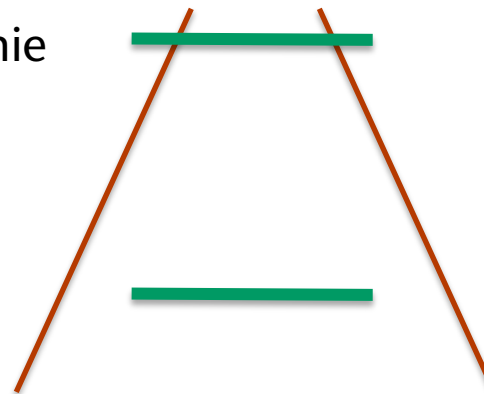

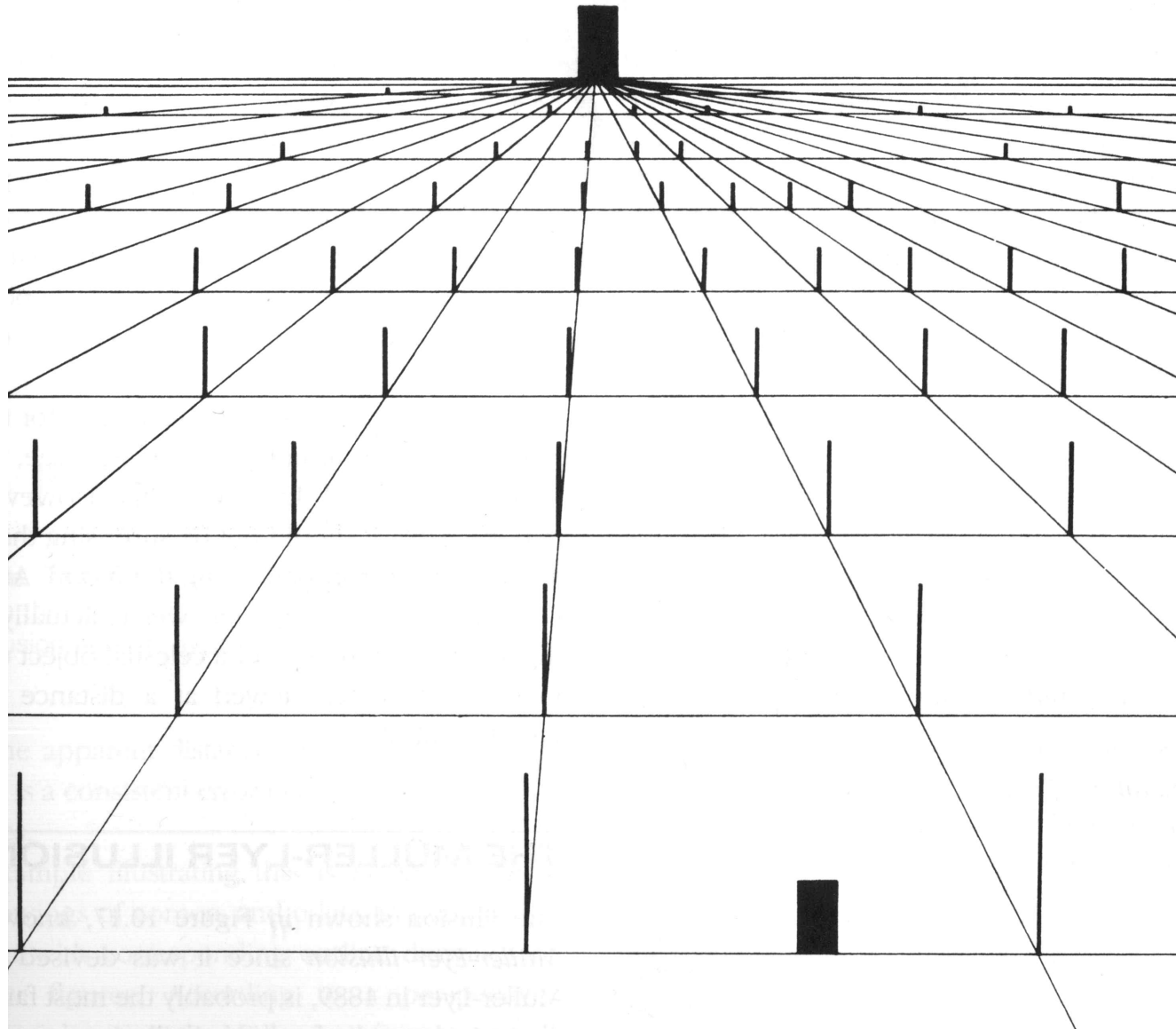



Die "Mond-Illusion"

- Die Ponzo-Illusion wurde auch beim Versuch der Erklärung der sog. "Mond-Illusion" (o.a. "Mond-Effekt") herangezogen
 - Die Mond-Illusion: der Mond erscheint am Horizont viel größer (ca. 1.5x) als im Zenith!
 - Sehr wahrscheinlich scheint die sog. "flat sky hypothesis":

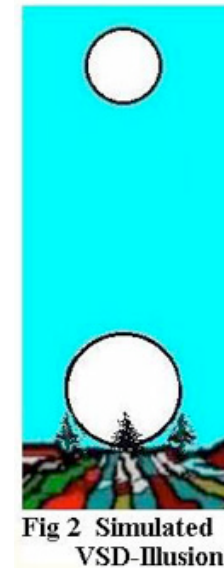
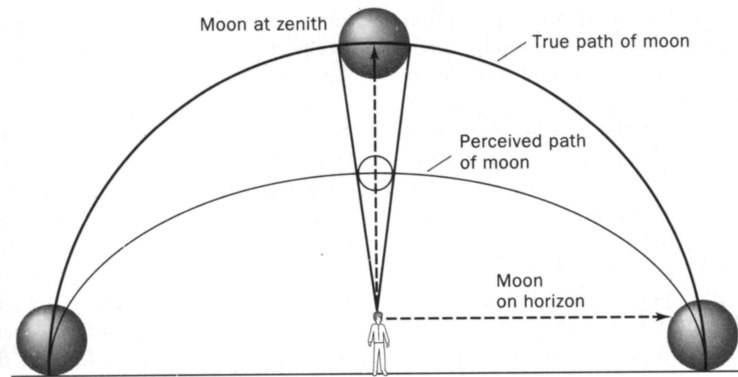
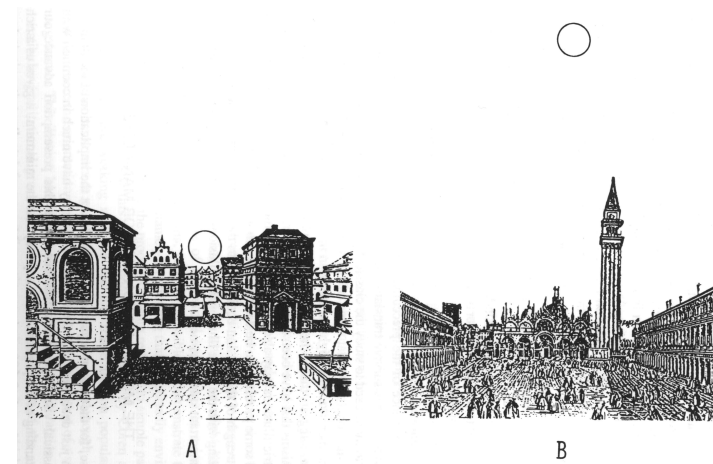

Fig 2 Simulated VSD-Illusion





The Leaning Tower Illusion



Die beiden Bilder sind identisch!



Frederick Kingdom, Ali Yoonessi and Elena Gheorghiu



- Die Ebbinghaus-Illusion:
 - Die orangen Kreise sind gleich groß!

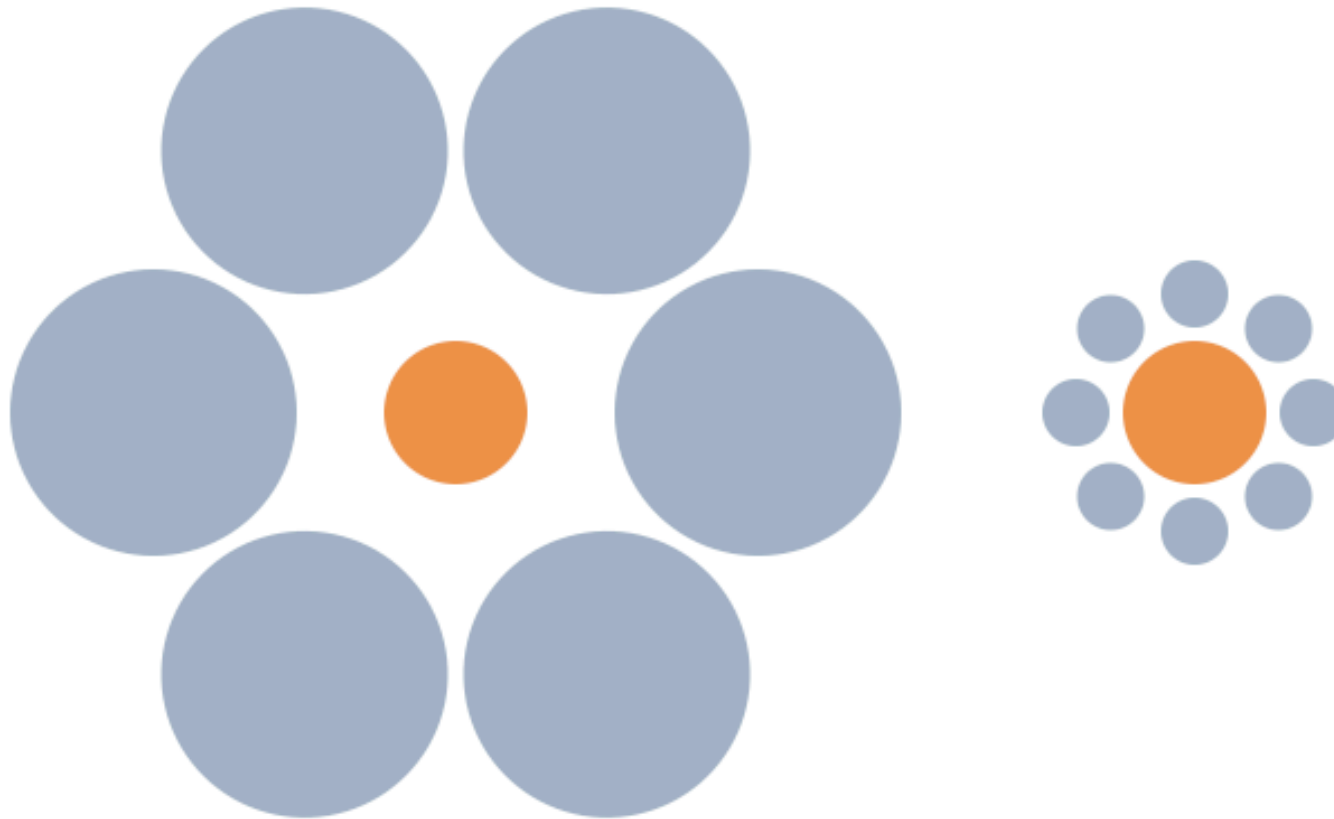



- Mögliche Erklärung der Ebbinghaus-Illusion:

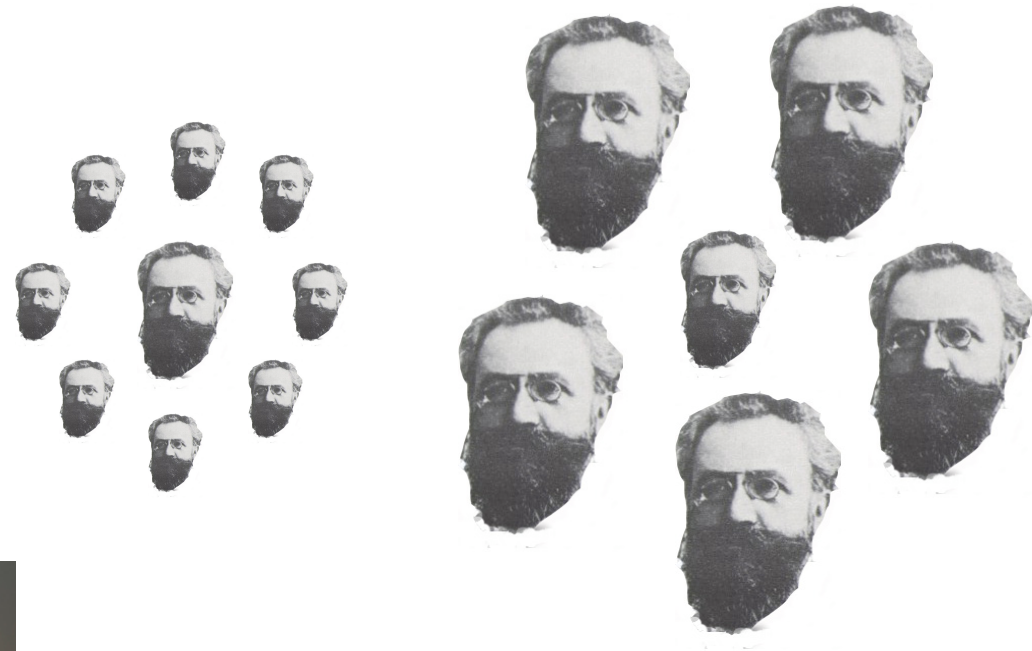



Die Zöllner-Illusion

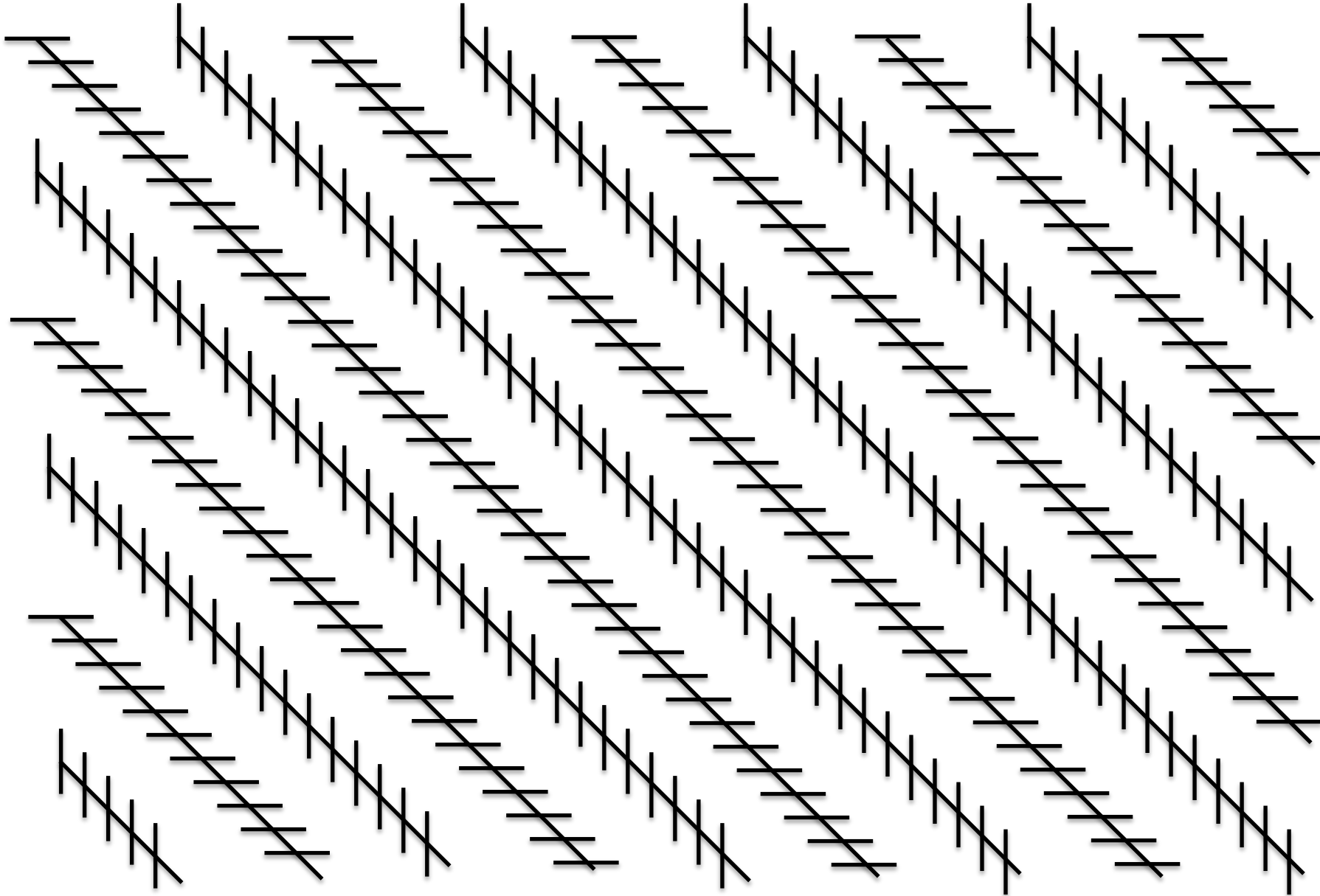



Anwendung



St. Jacobi
in Göttingen
(1391-1400)





Die Hering-Illusion

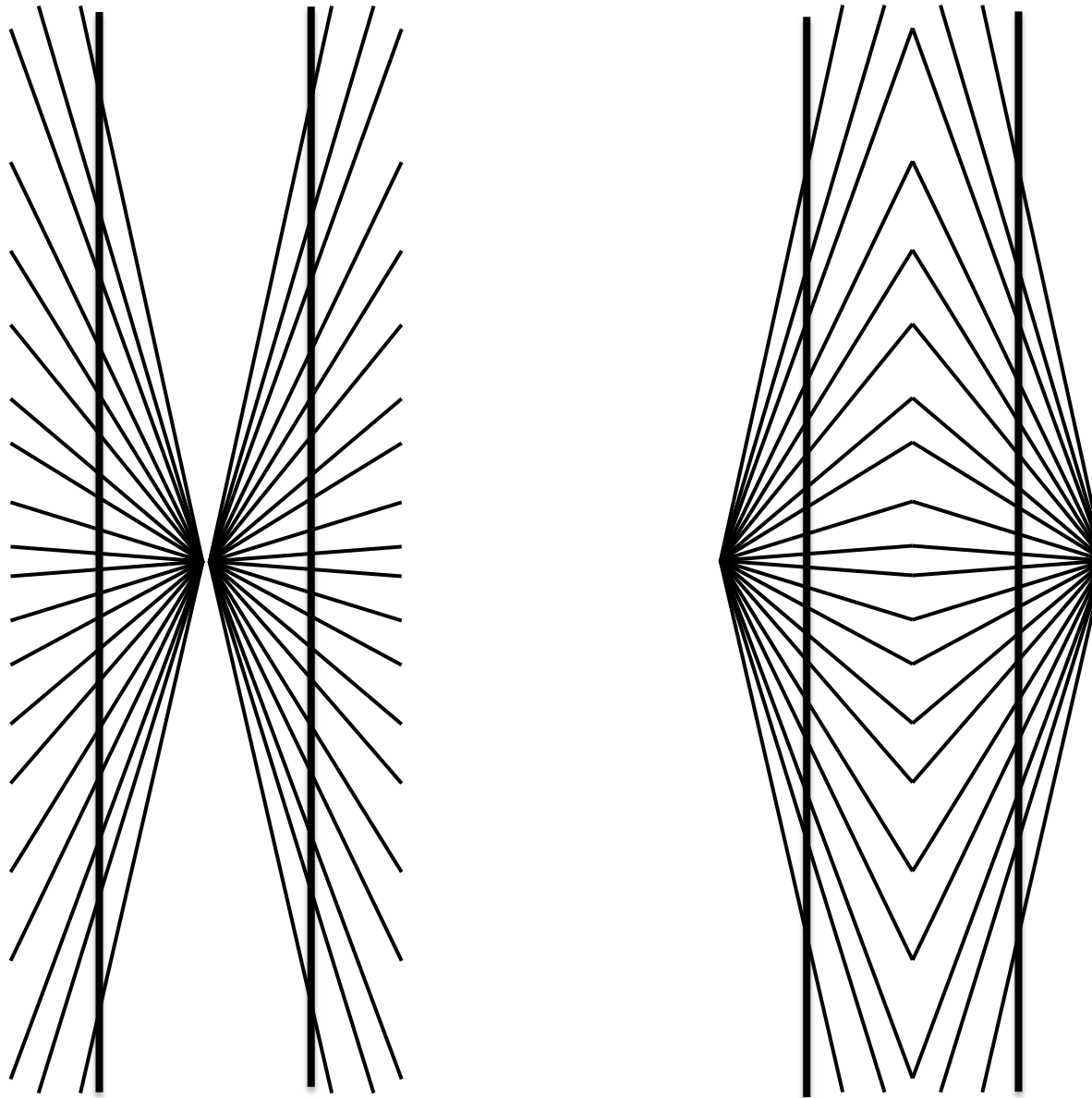

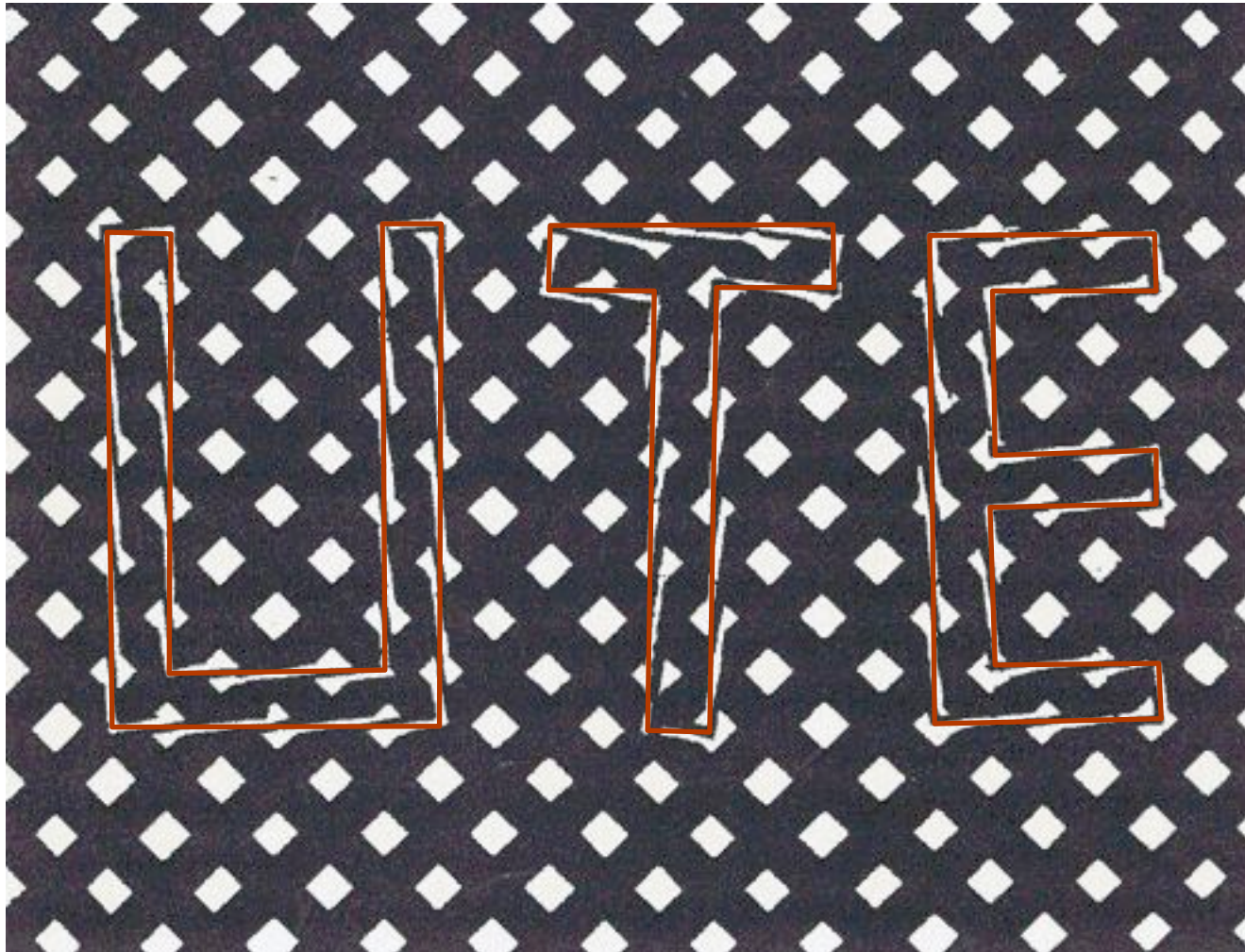



Ehrenstein-Illusion

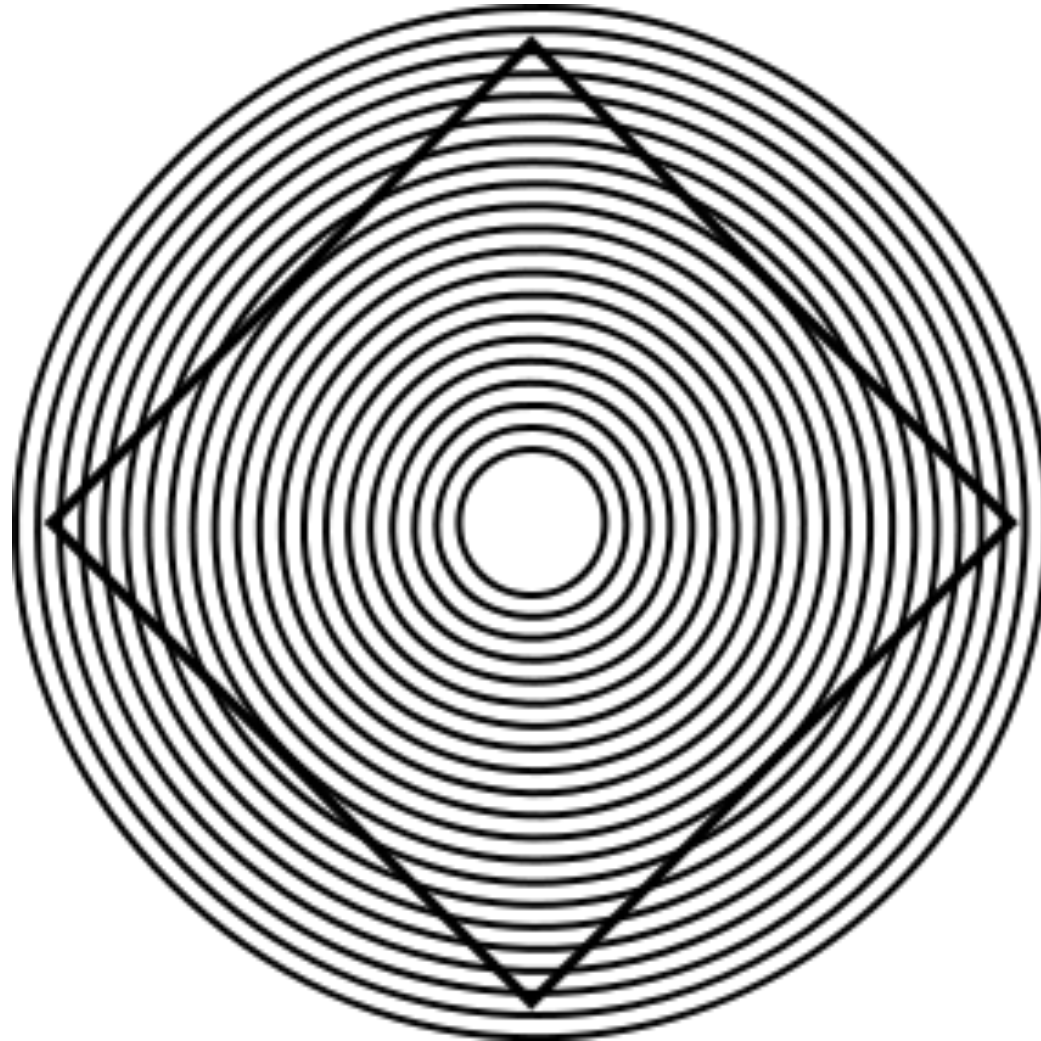



The Café Wall Illusion

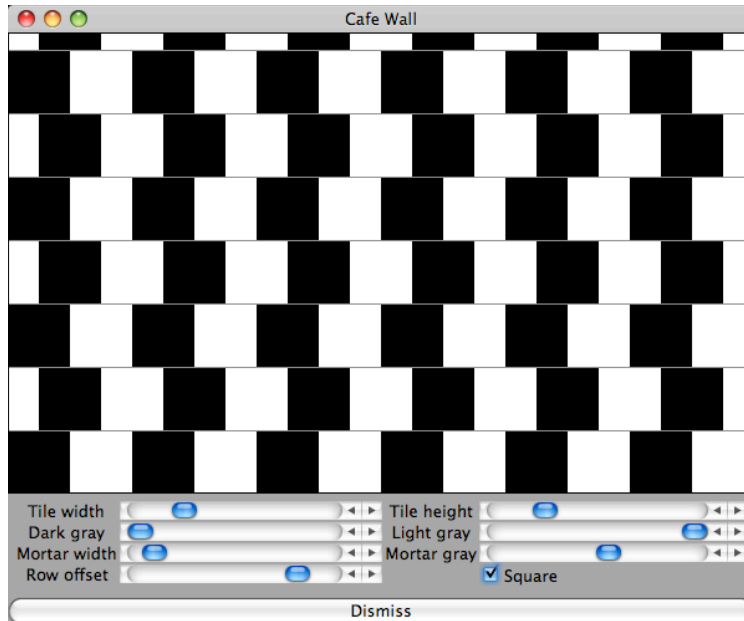

Courtesy Dr. Gregory

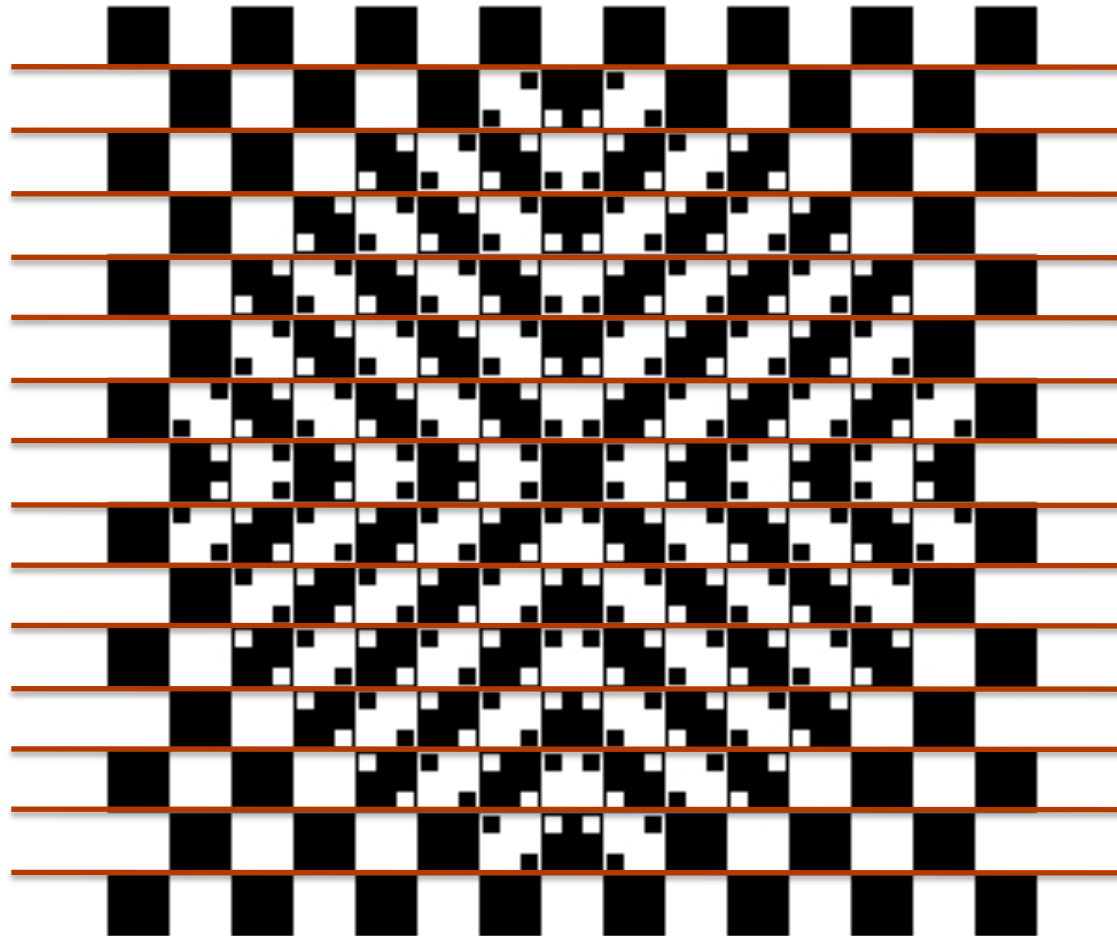



Fraser's Spirale

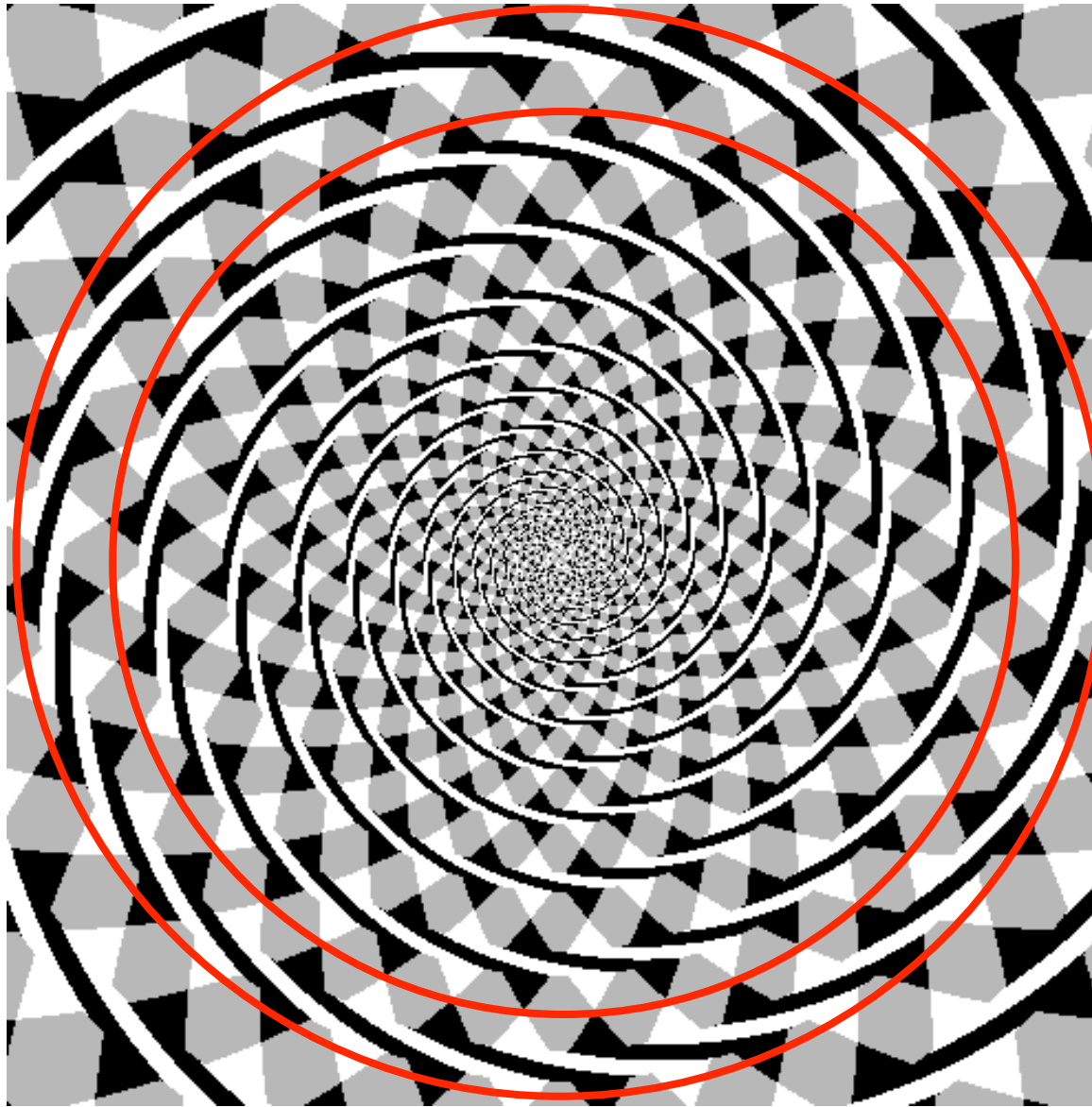



Varianten

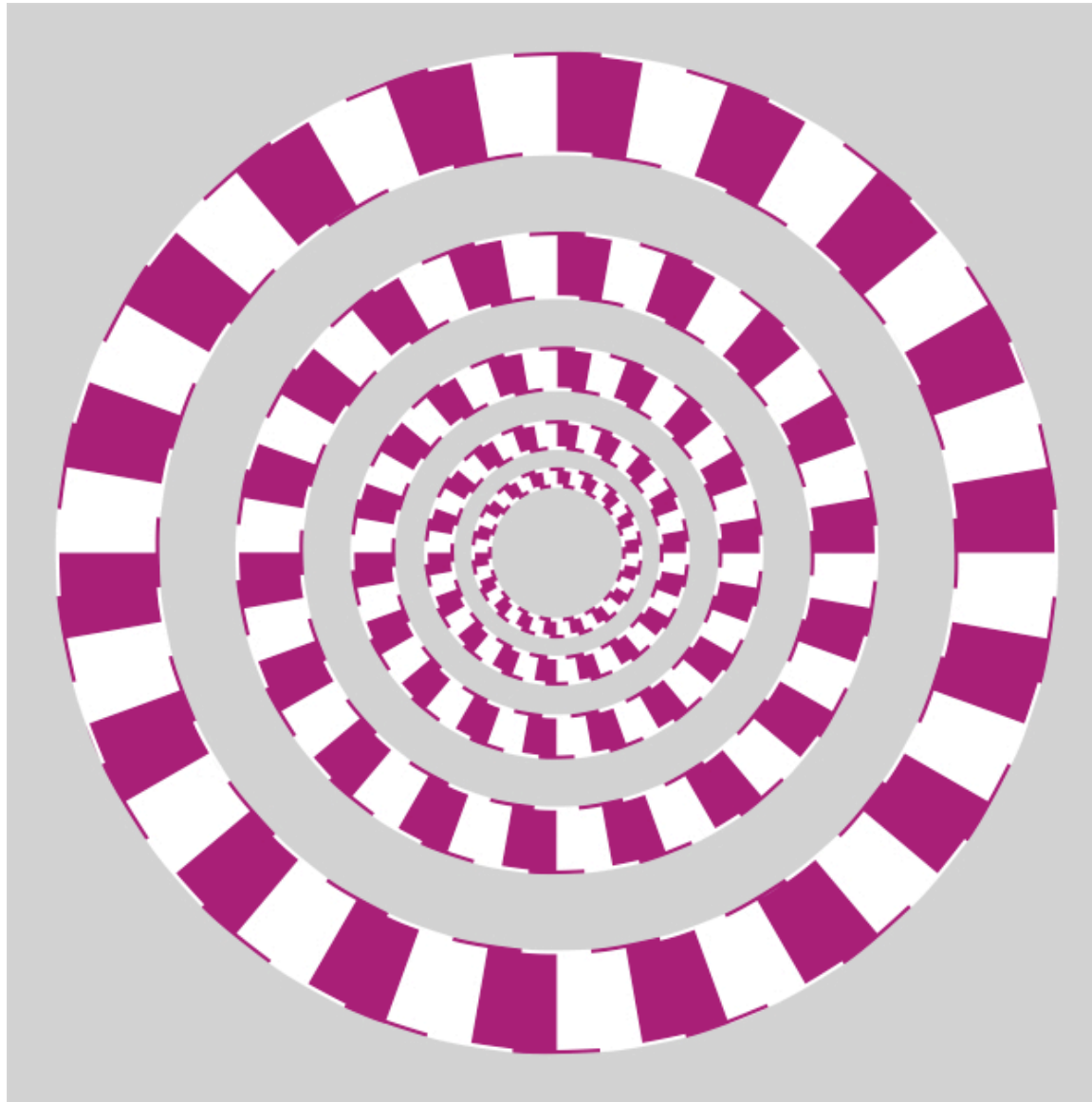

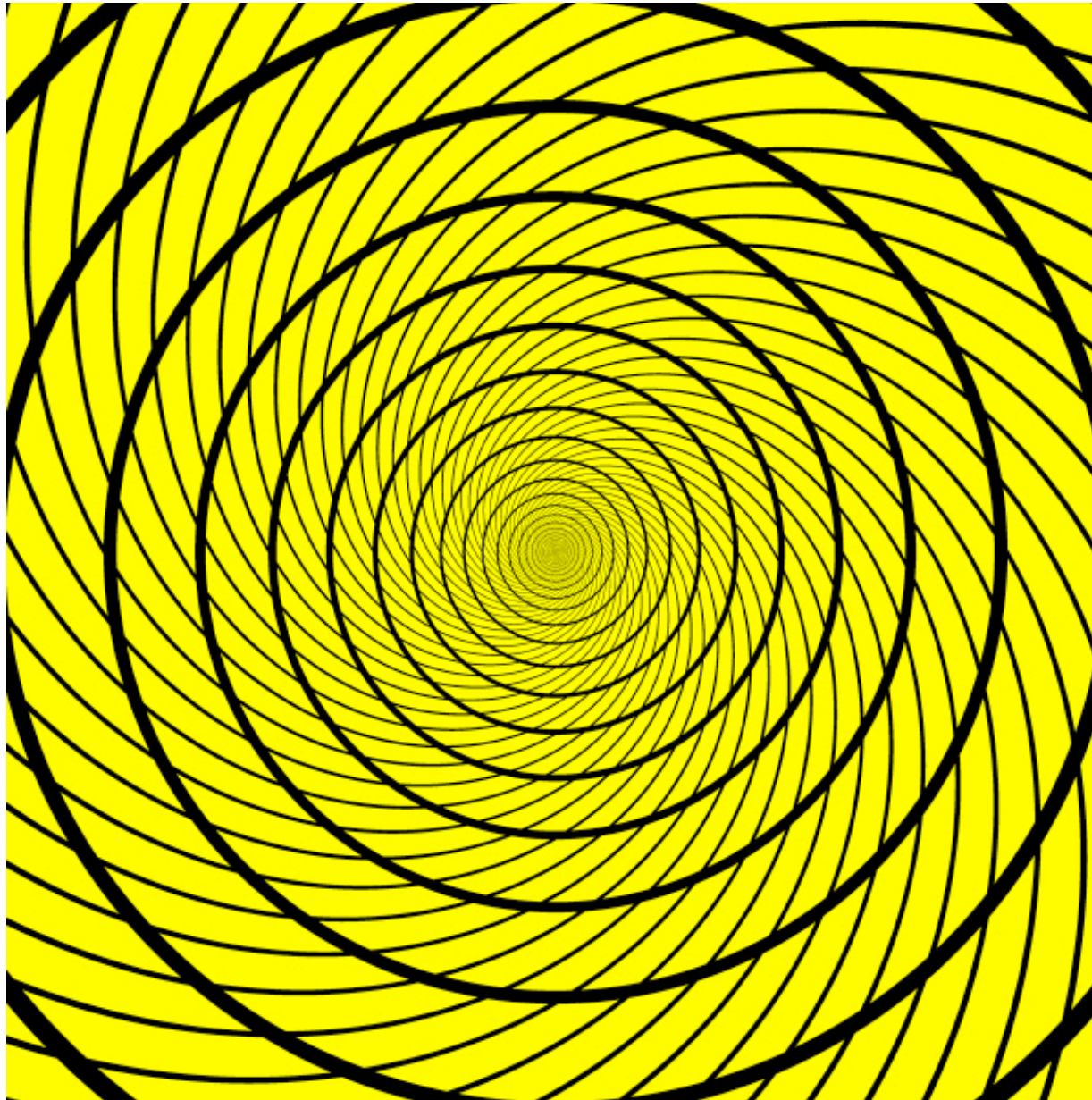



Roget's "Palisade" Illusion

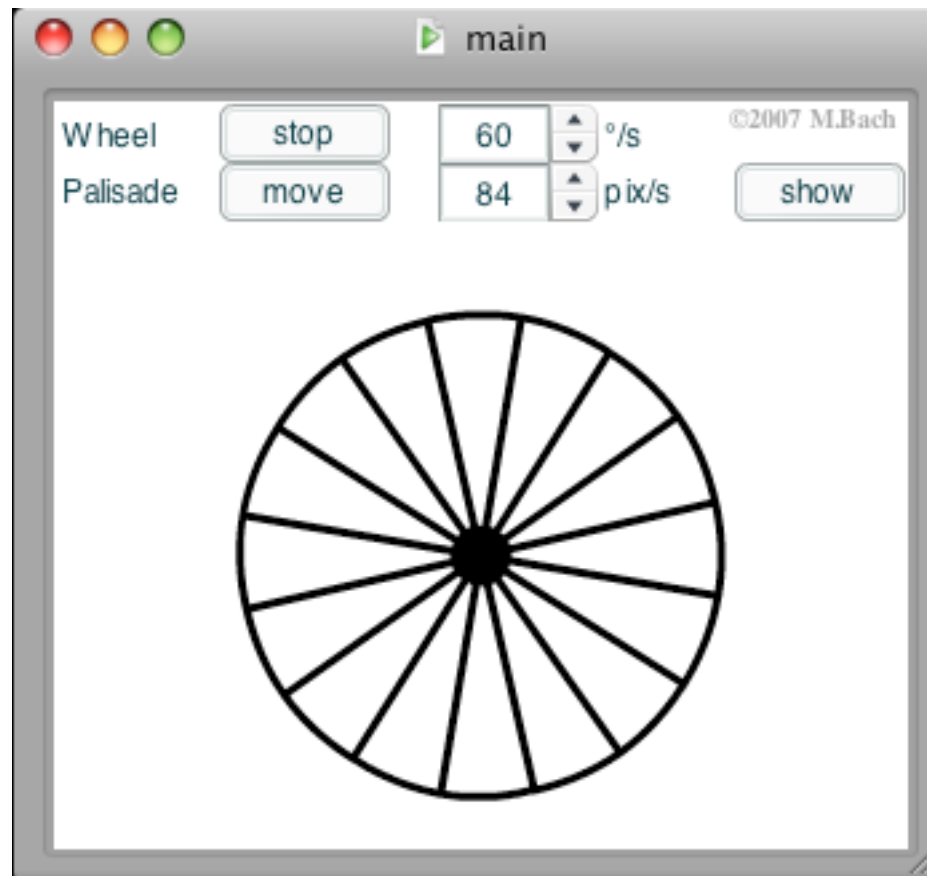



Gestalt-Effekte

- Kanizsa's Dreieck:

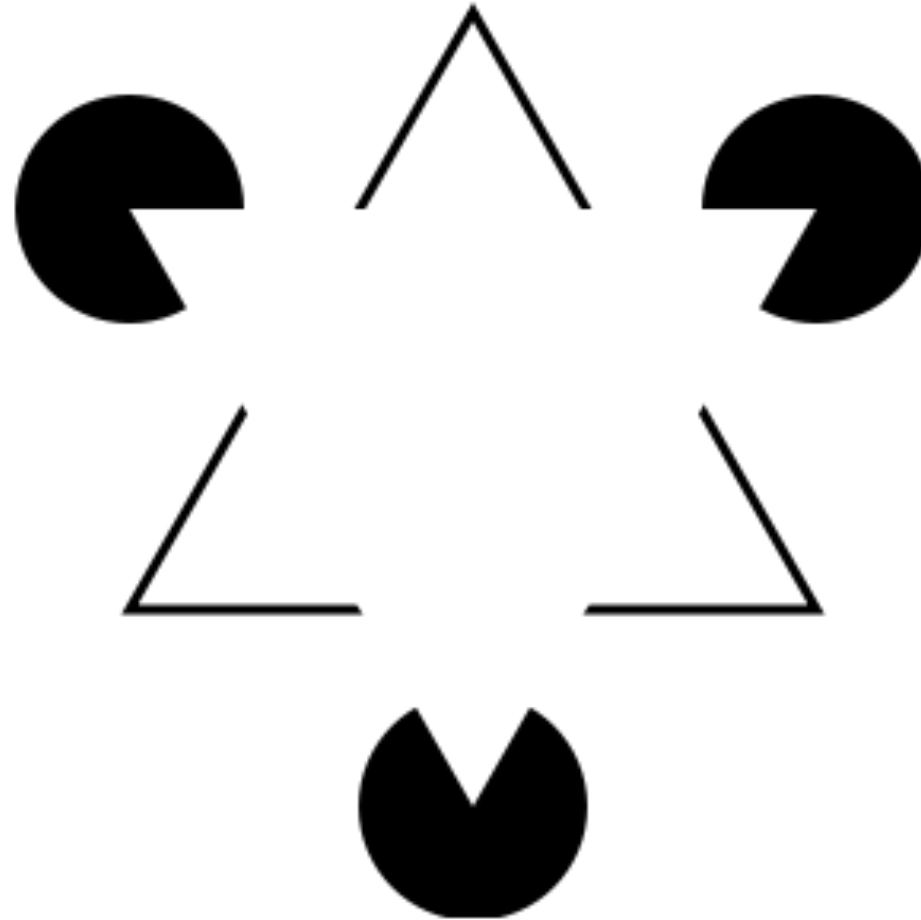



Motion Binding

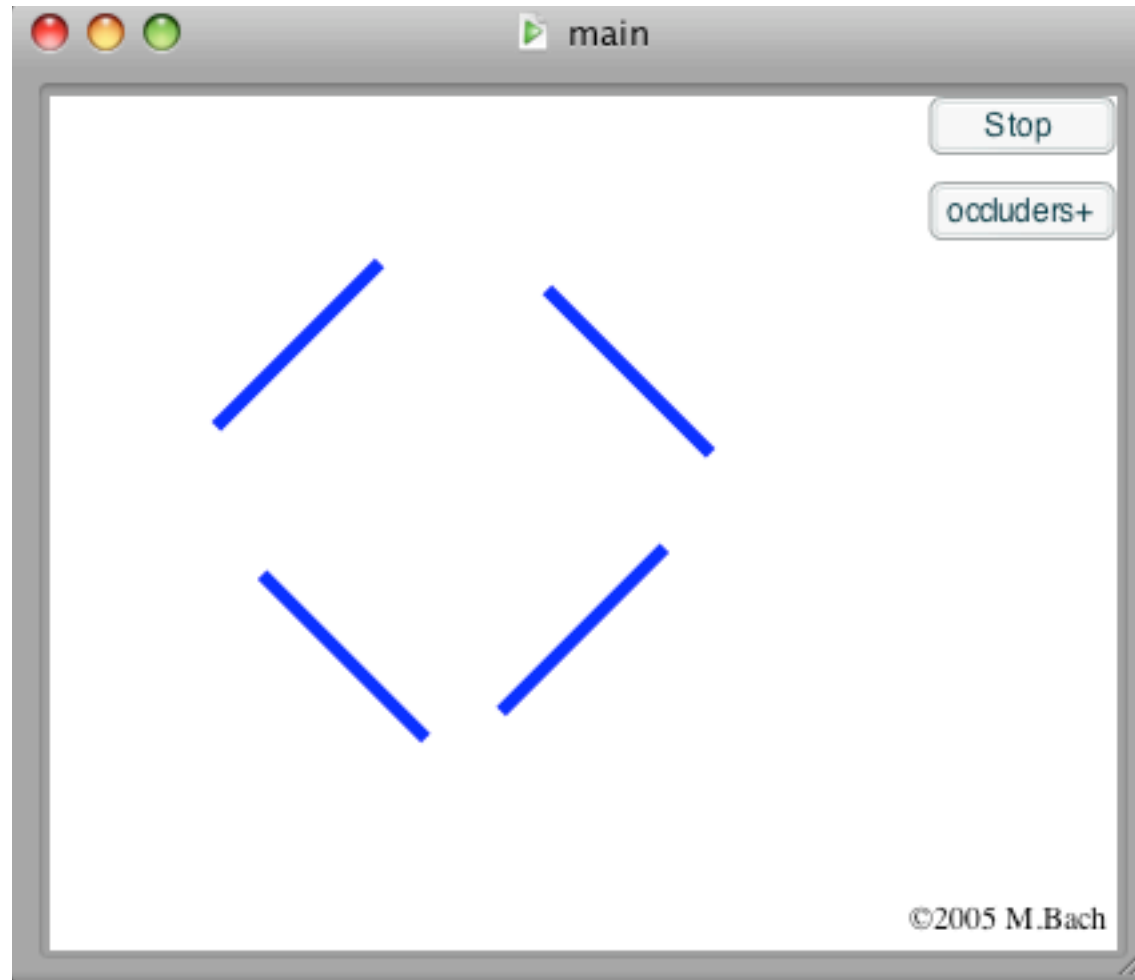



www.michaelbach.de



Der Dalmatiner



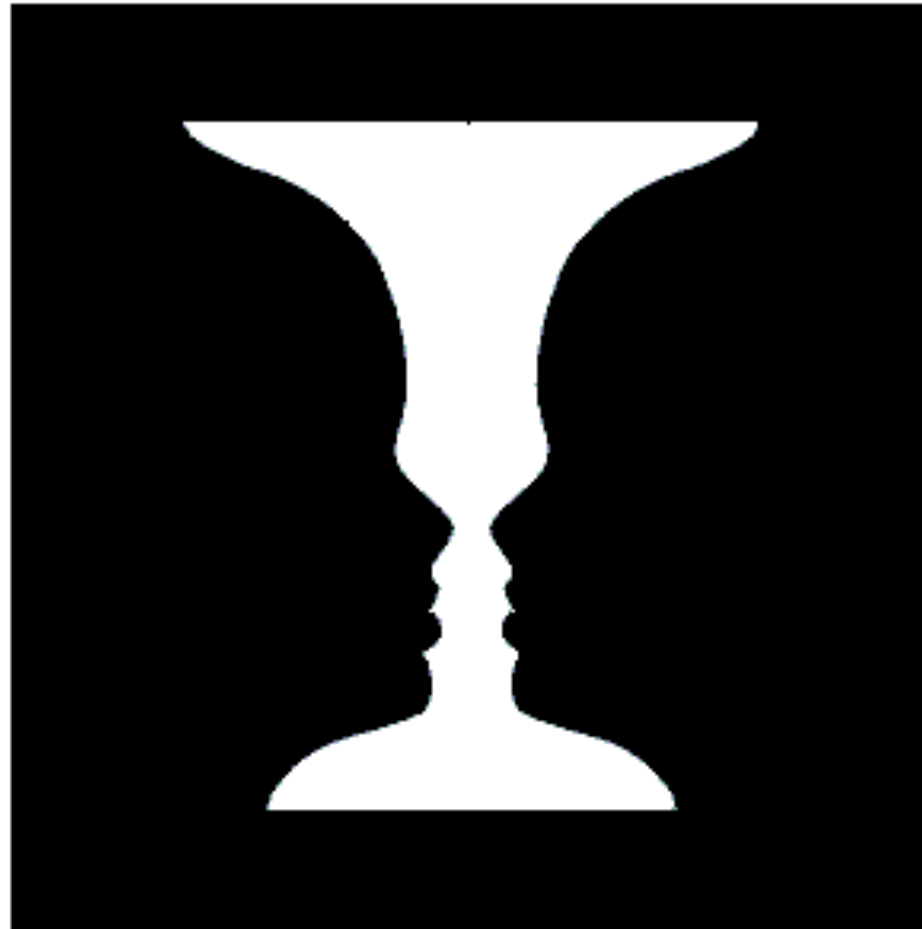

Eine Vase – oder zwei Köpfe im Profil?



WHAT'S ON A MAN'S MIND





Figur-Hintergrund-Problem: Gesetz der relativen Größe

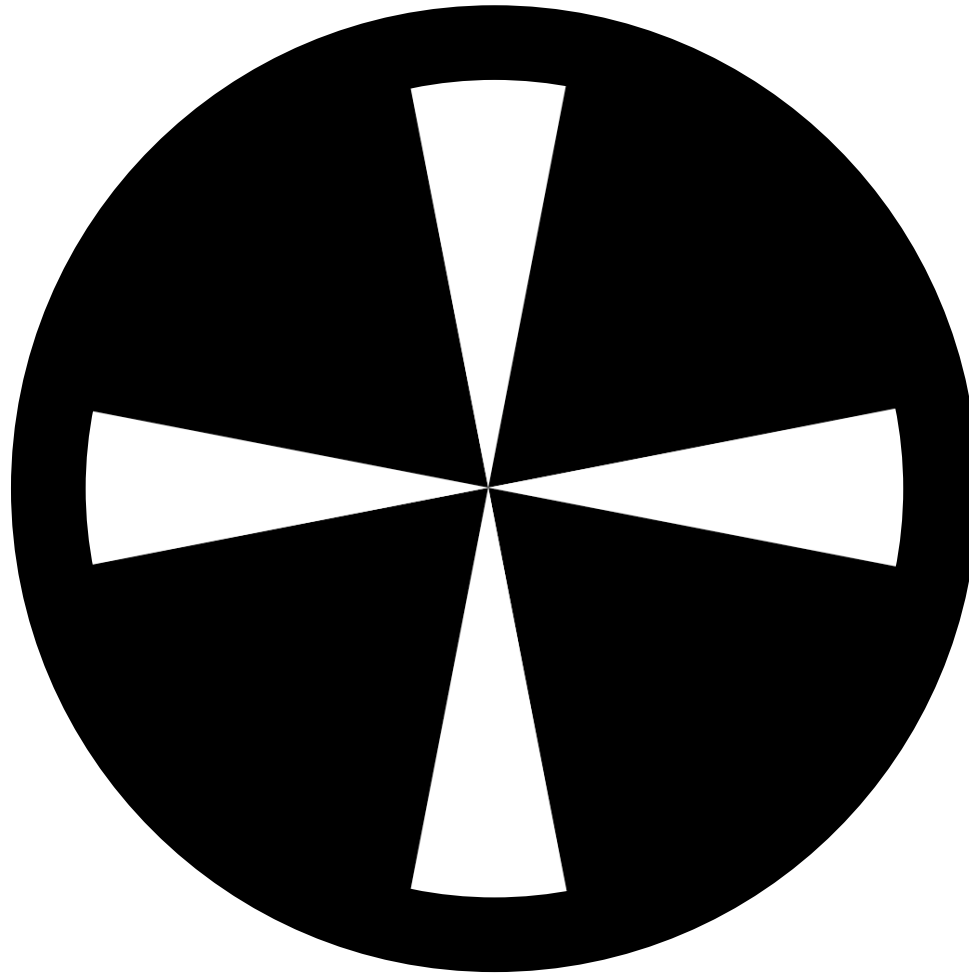



Visuelles Phantom

- Die drei vertikalen "Dunst"-bänder scheinen sich im Vordergrund zu befinden und die homogene, horizontale, graue Region zu "überbrücken":

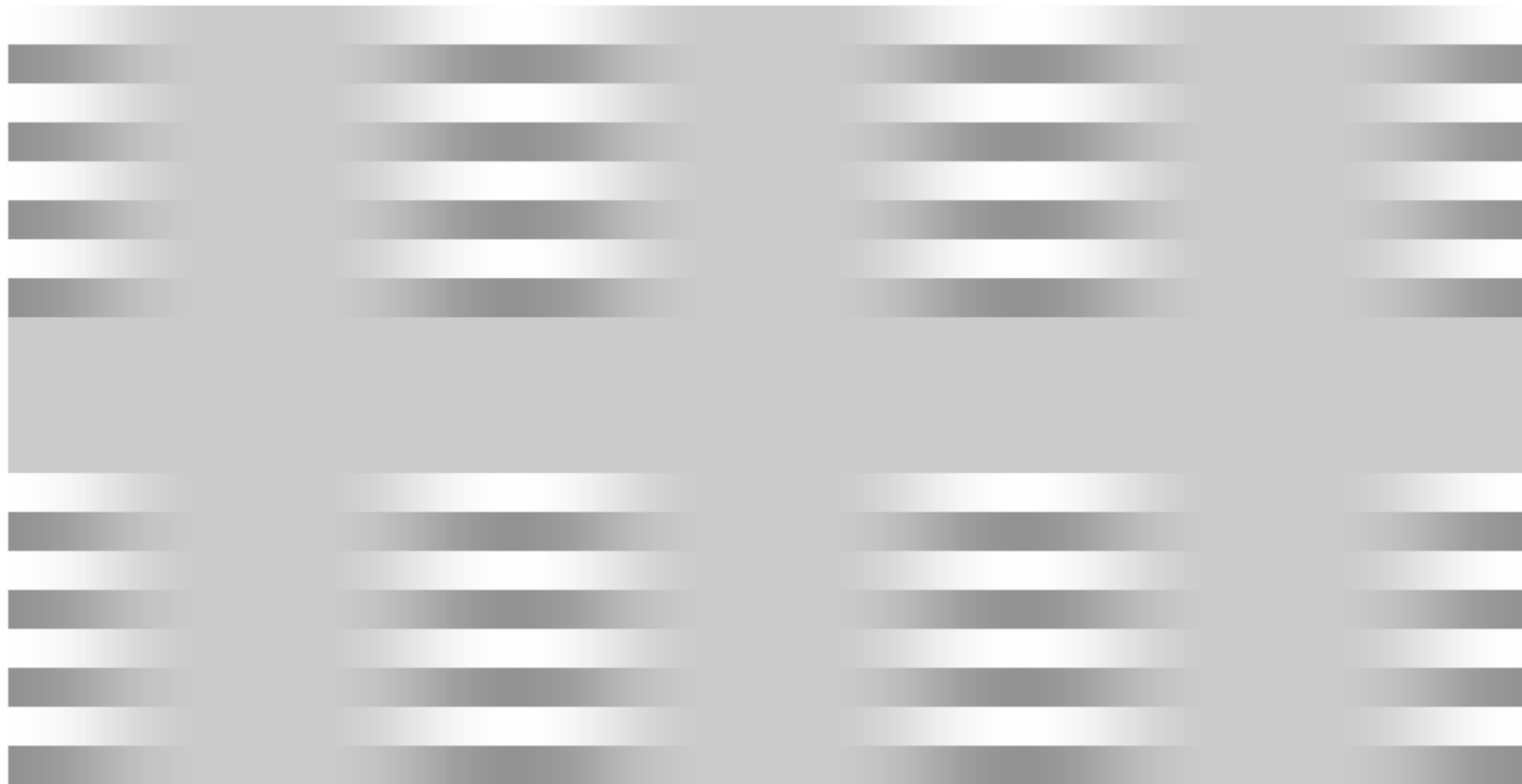



Coffer Illusion

- How many circles do you see?

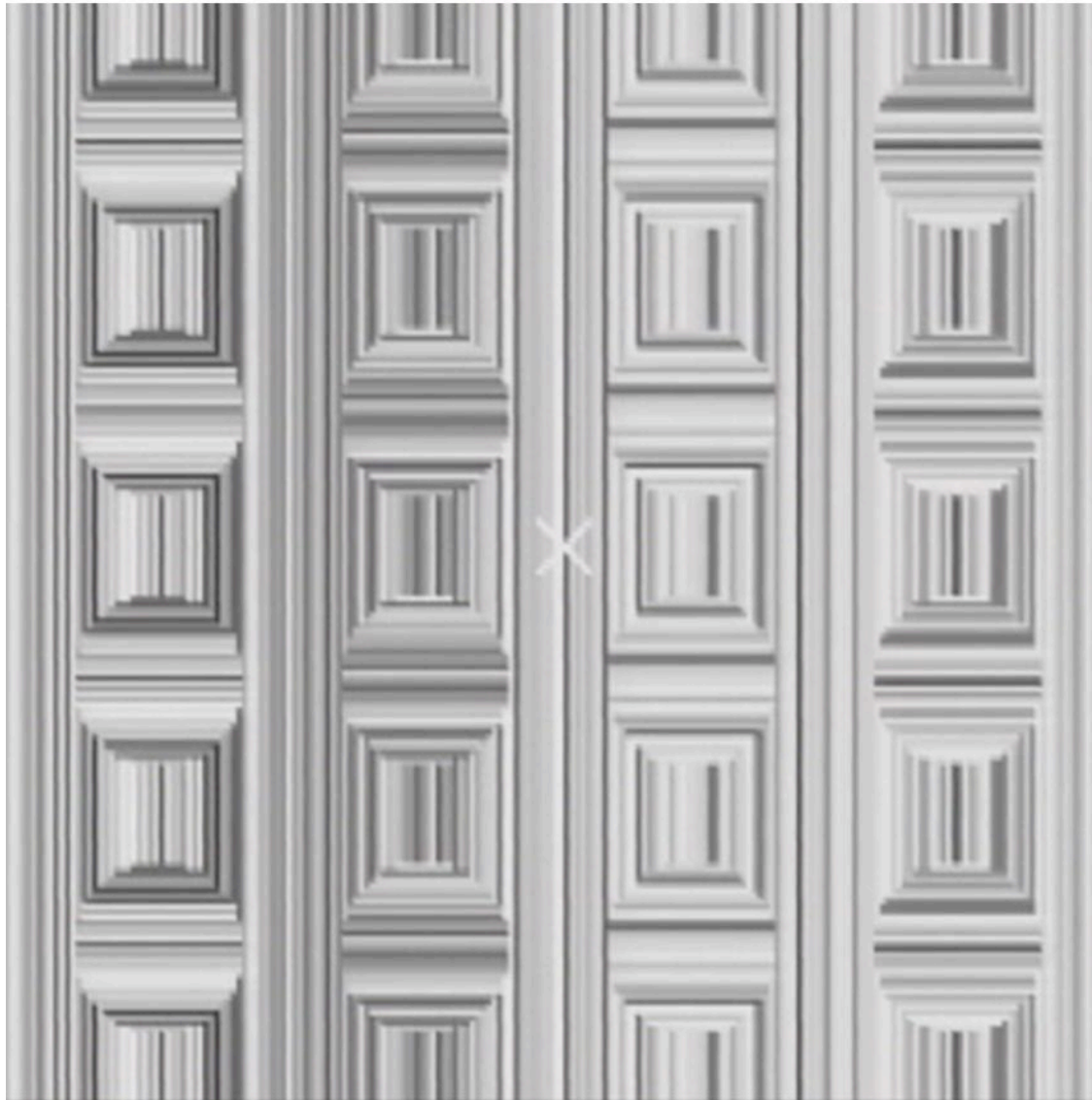

Anthony Norcia; 2006





Scheinbare Bewegung

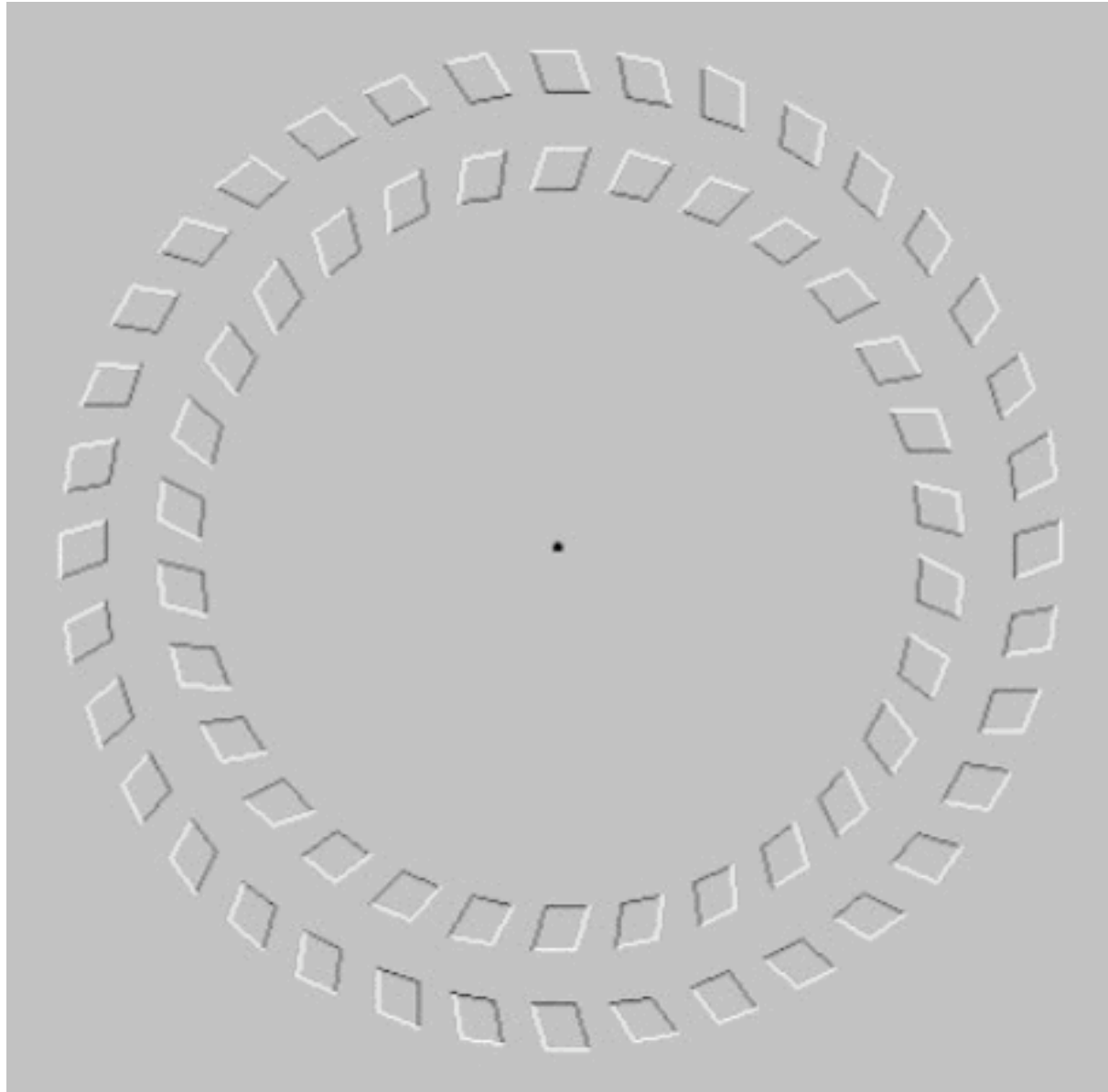

Schauen Sie auf den Punkt in der Mitte
und bewegen Sie den Kopf vor und zurück!

Pina &
Brellstaff,
2000

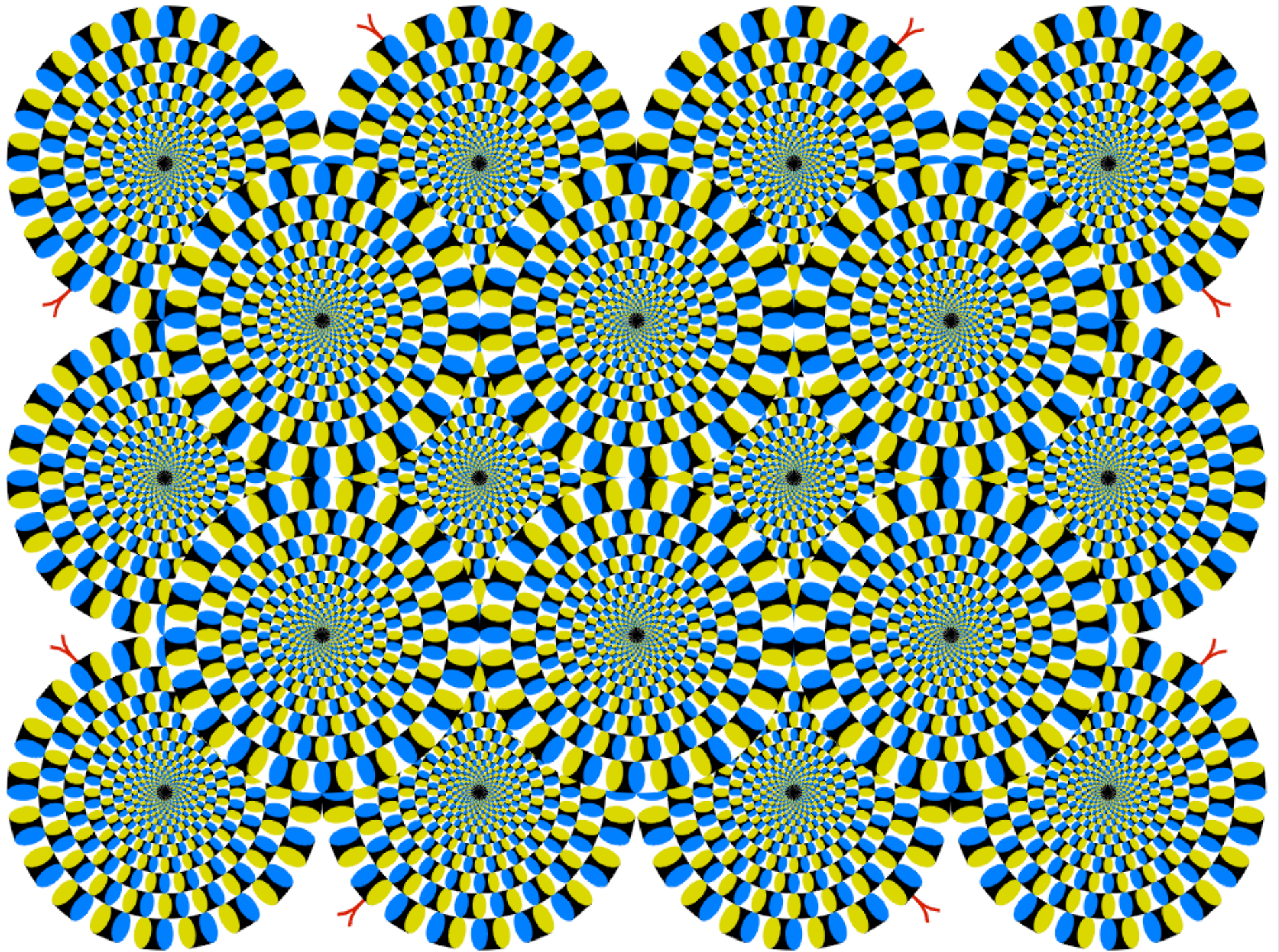

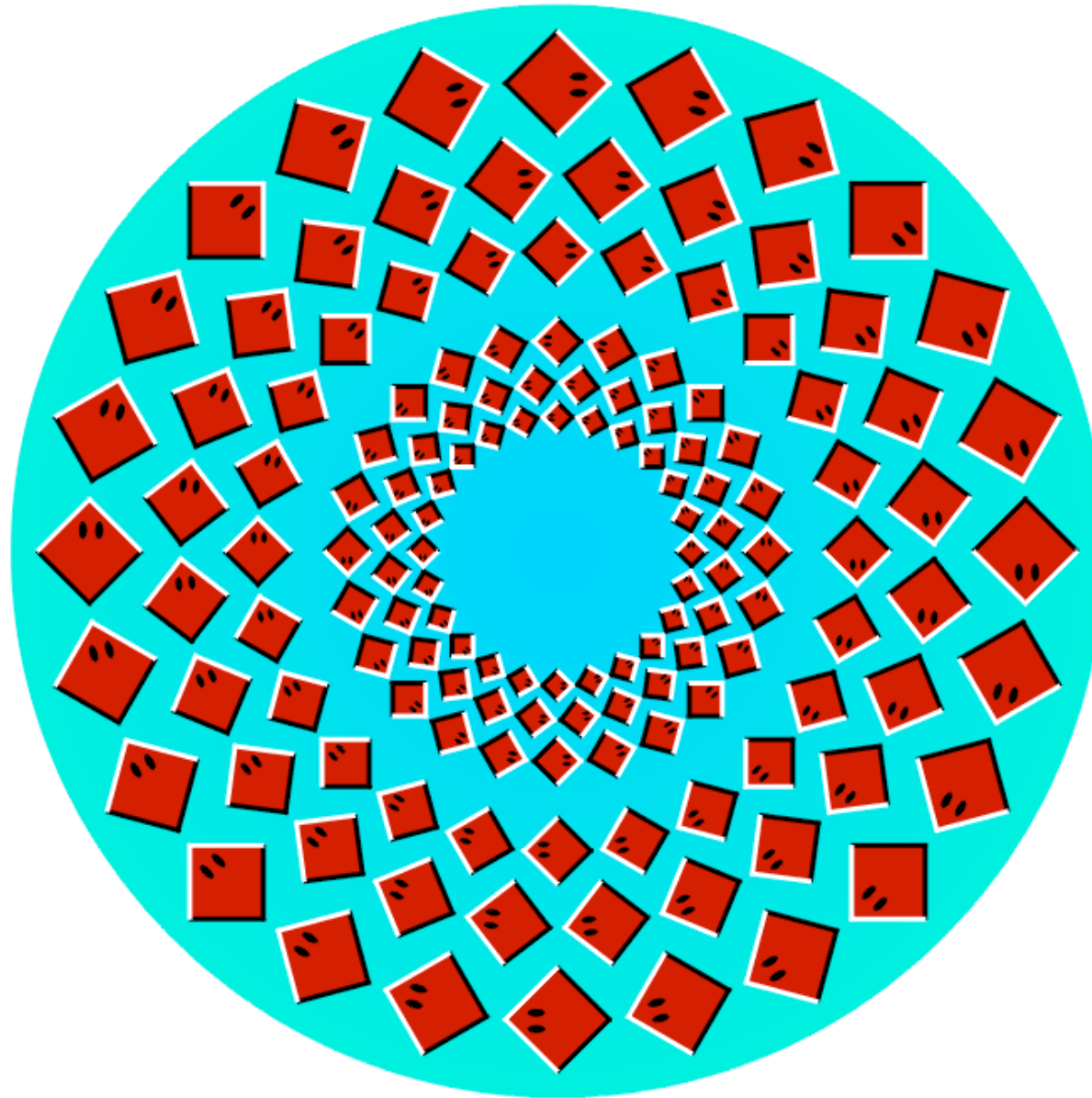

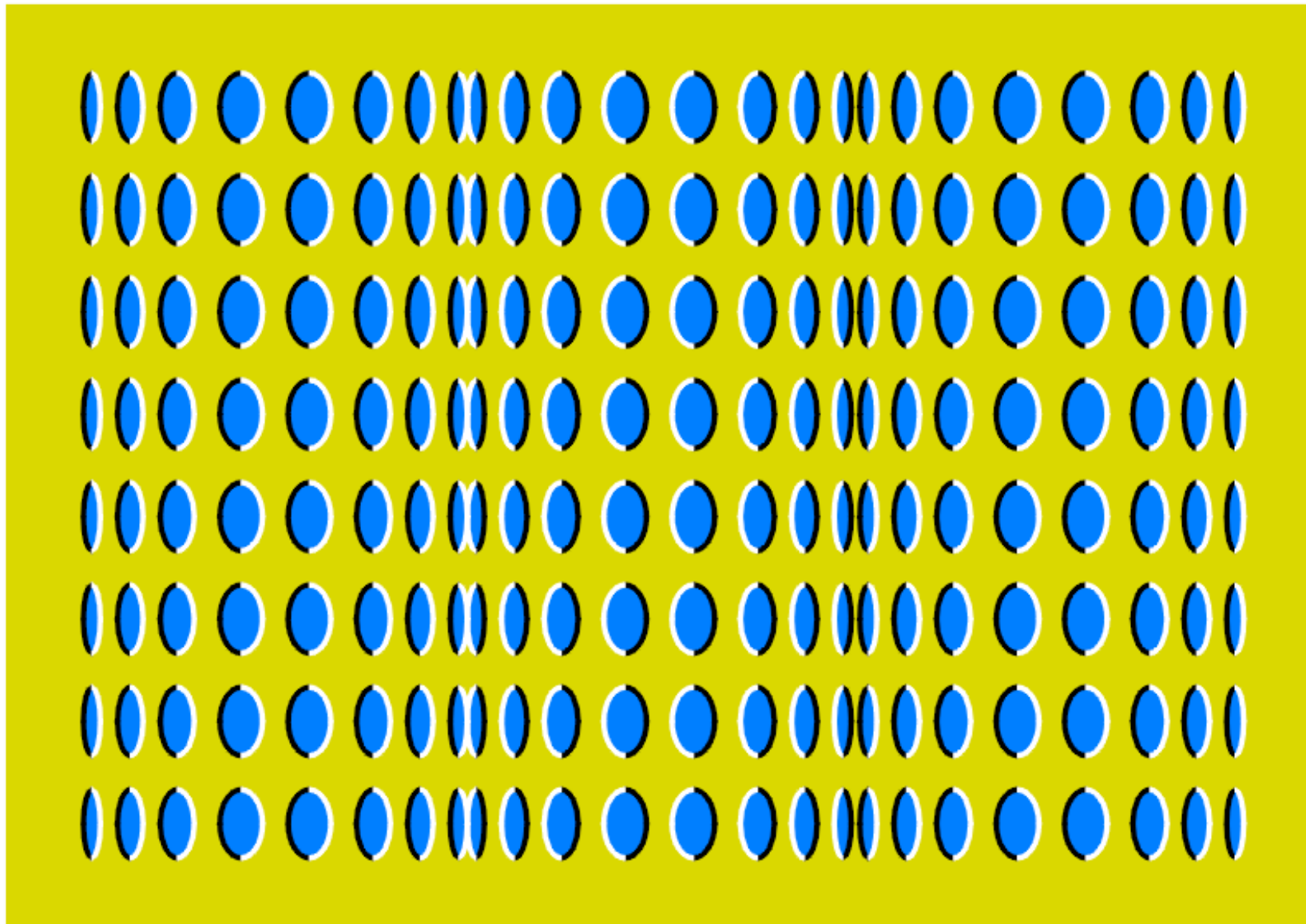

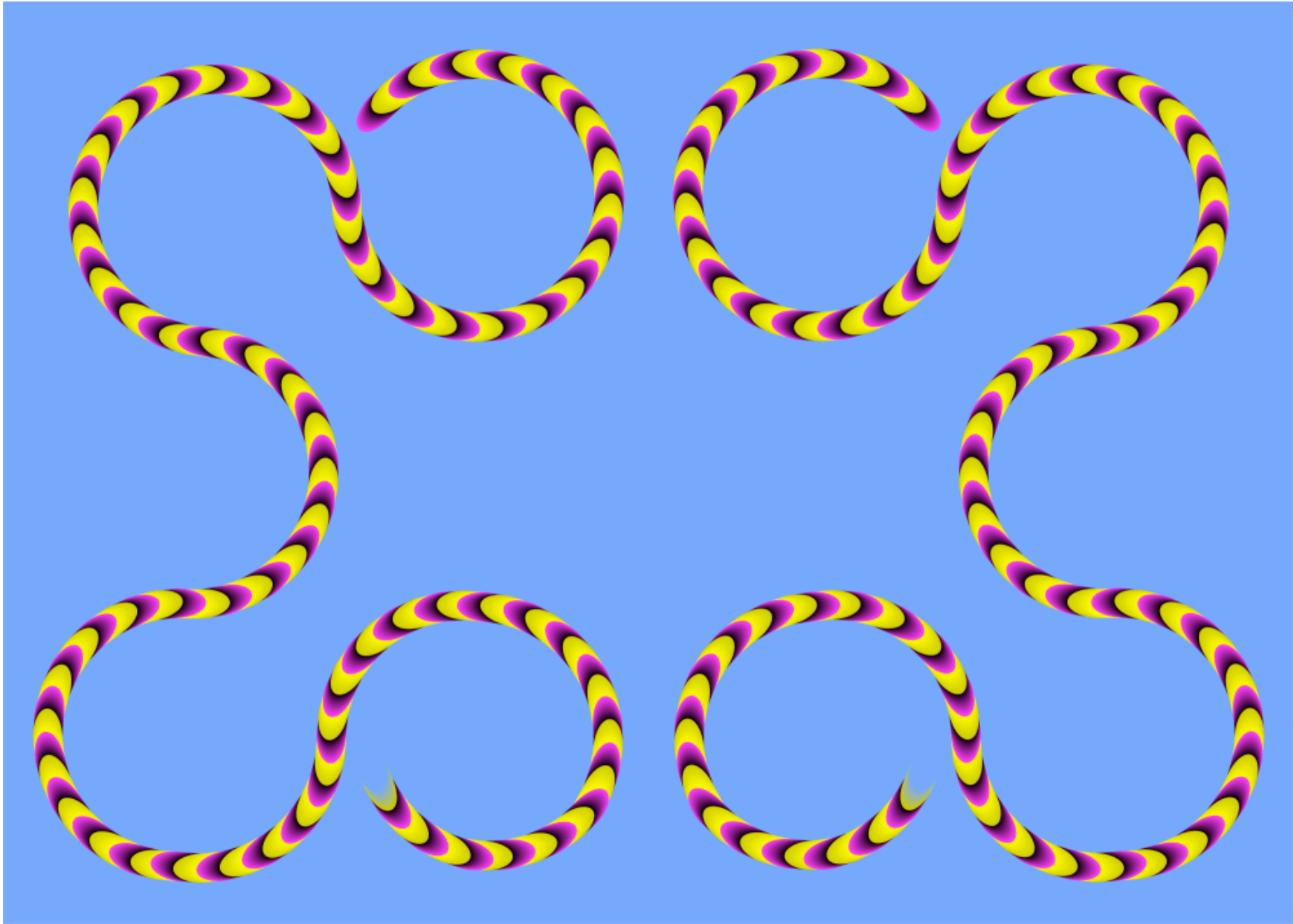

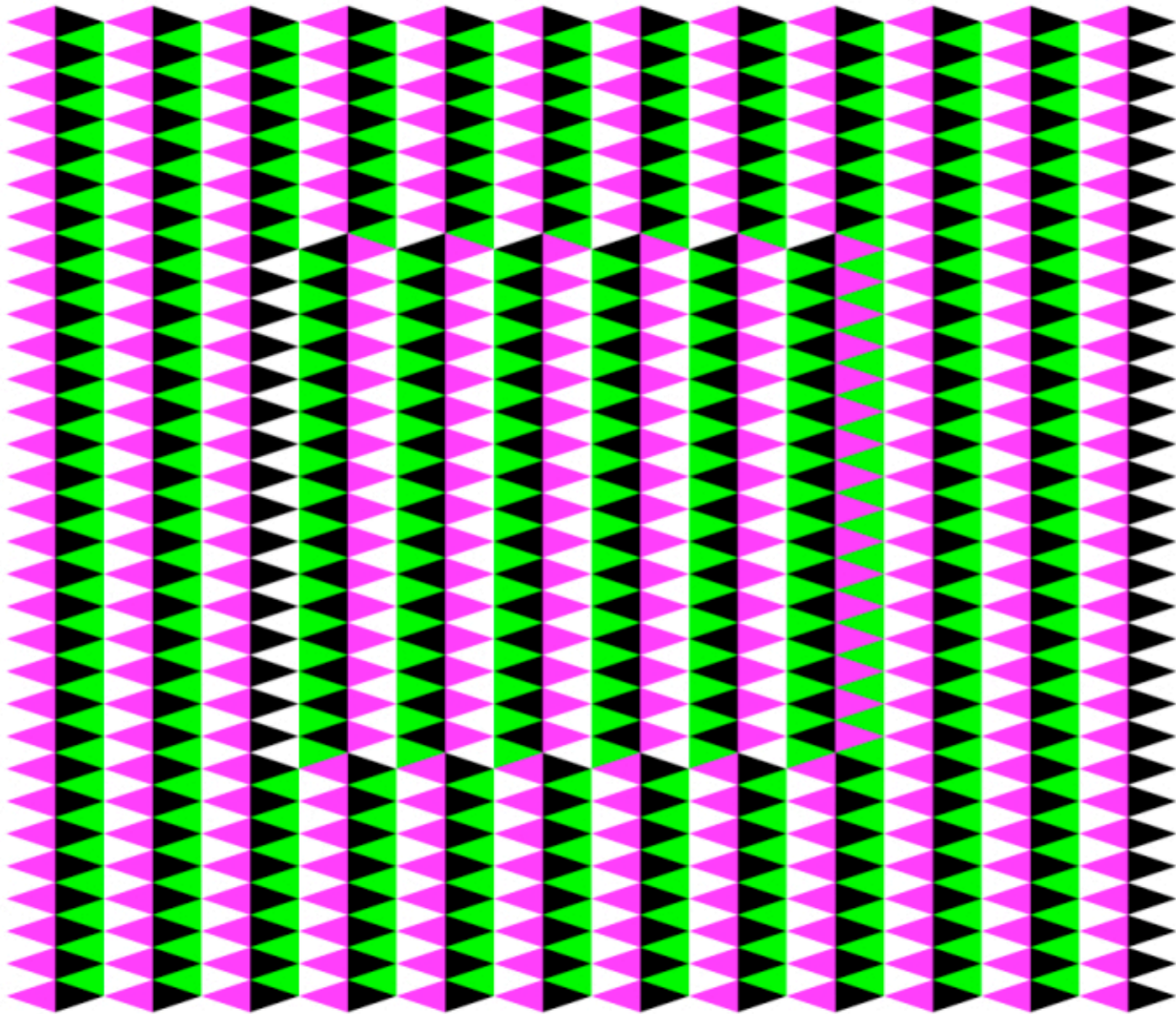

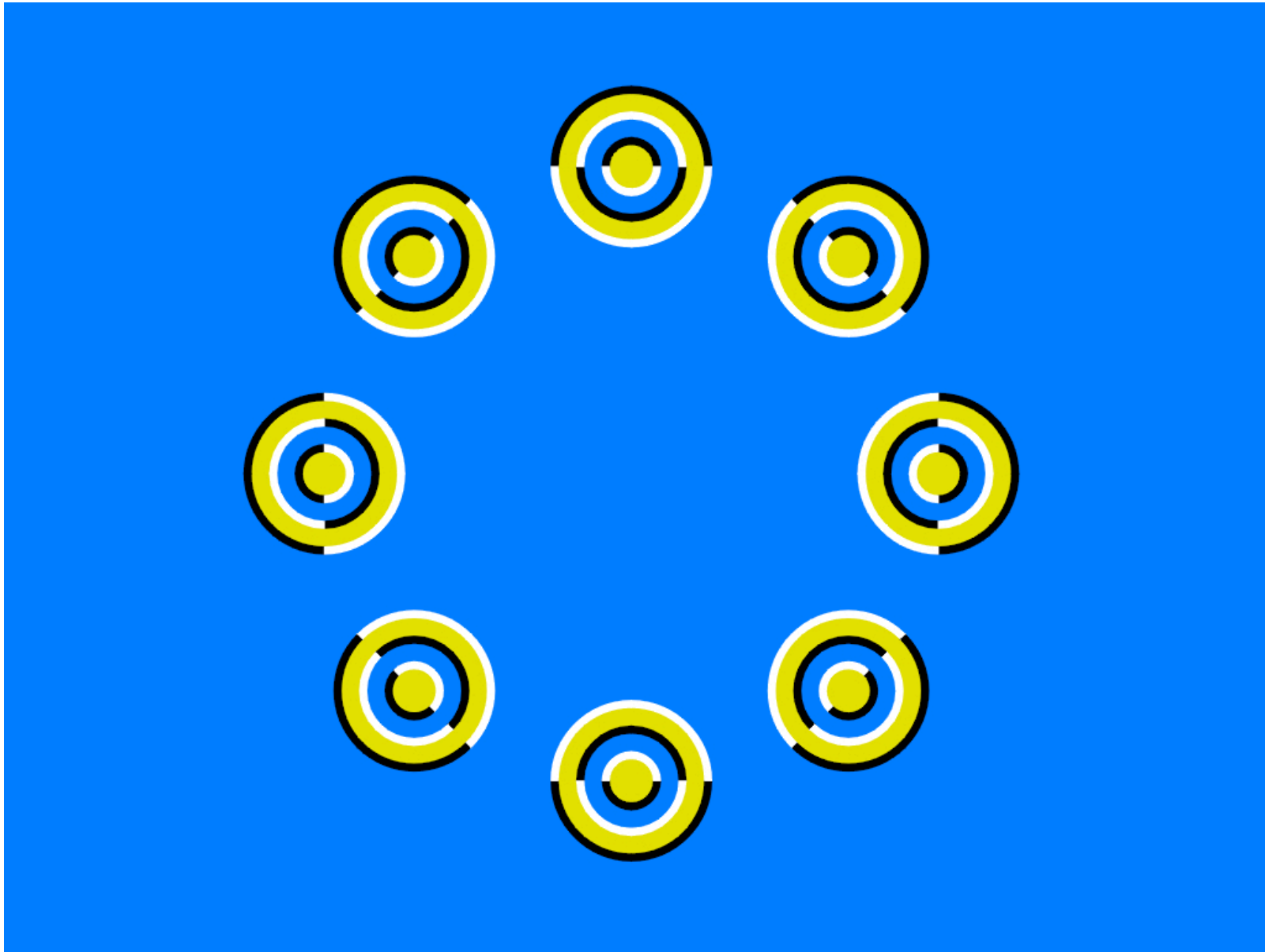

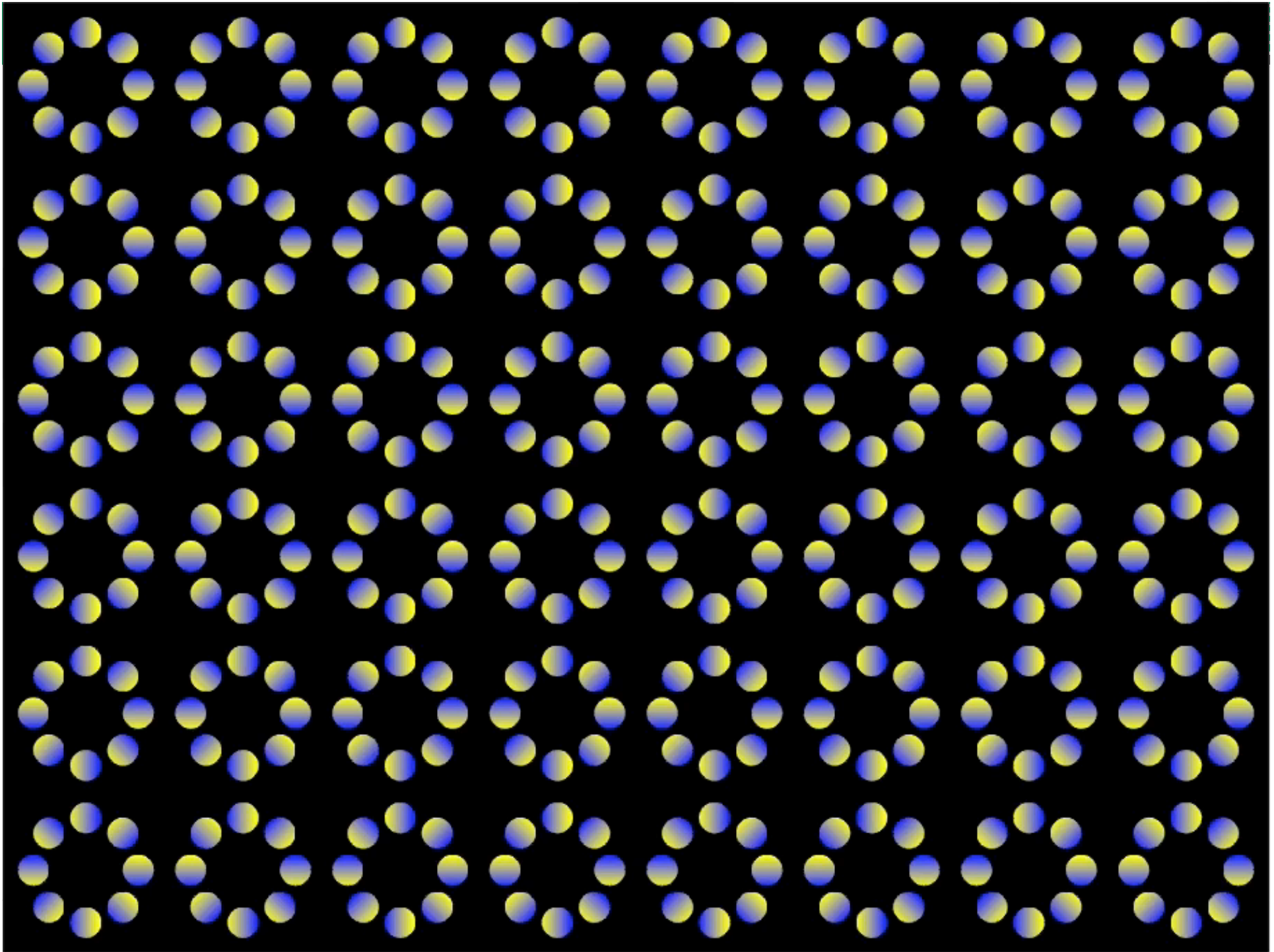

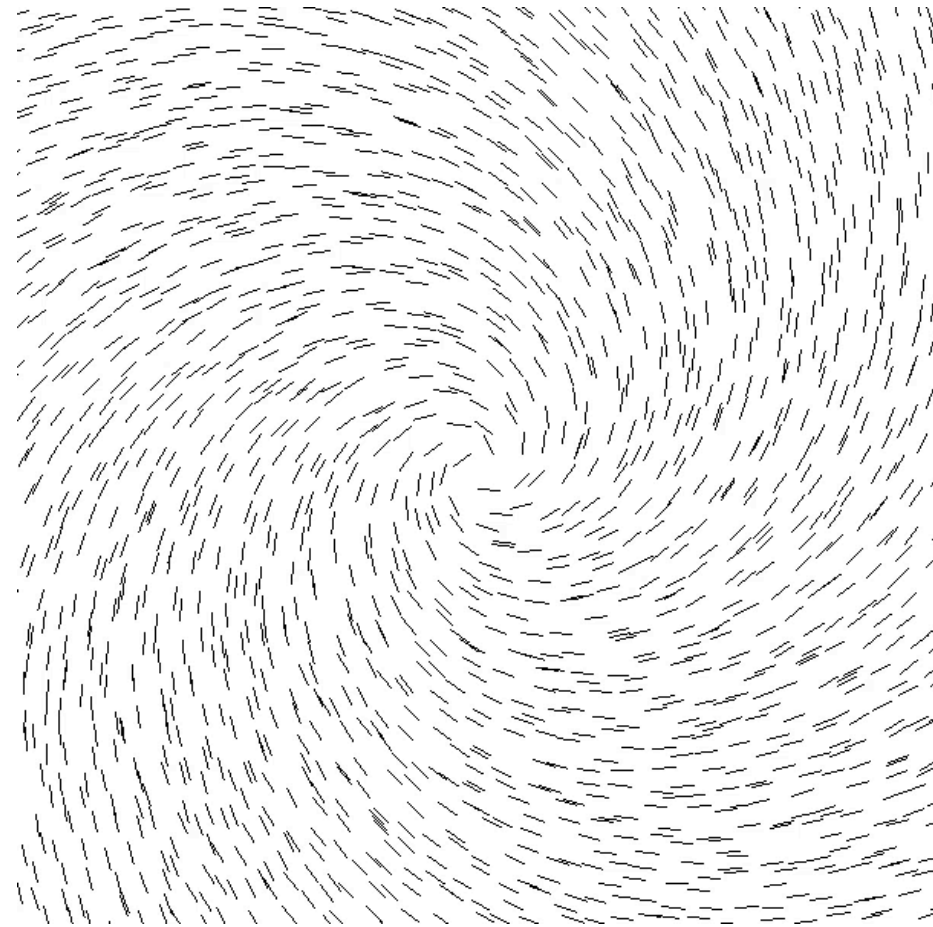

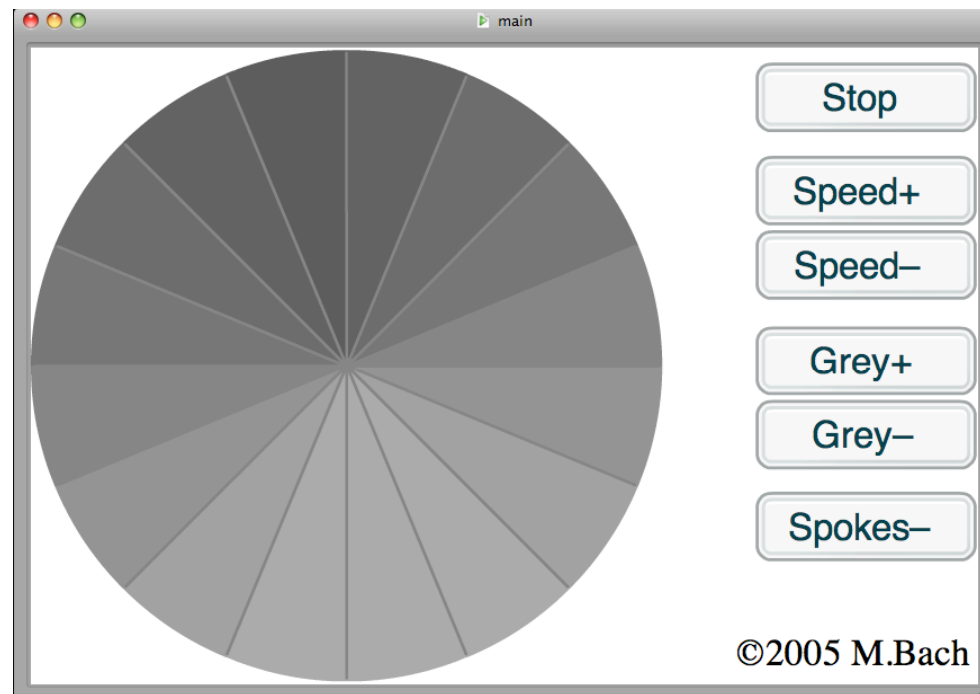

Invented by Anstis & Rogers in 2001; presented at the ARVO 2001.
Programmed by Michael Bach.



Kombination Spiral-Illusion mit scheinbarer Rotation

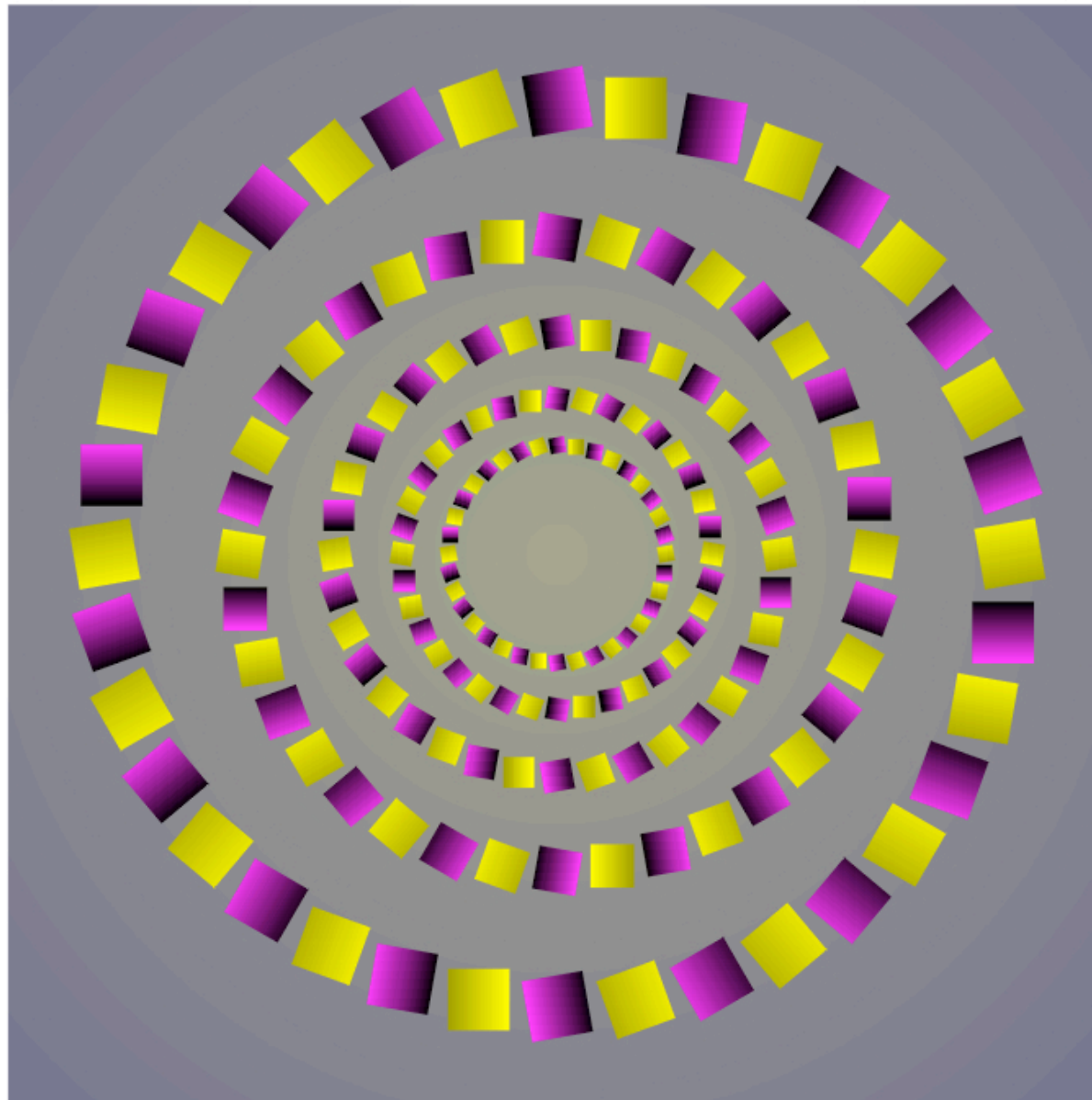

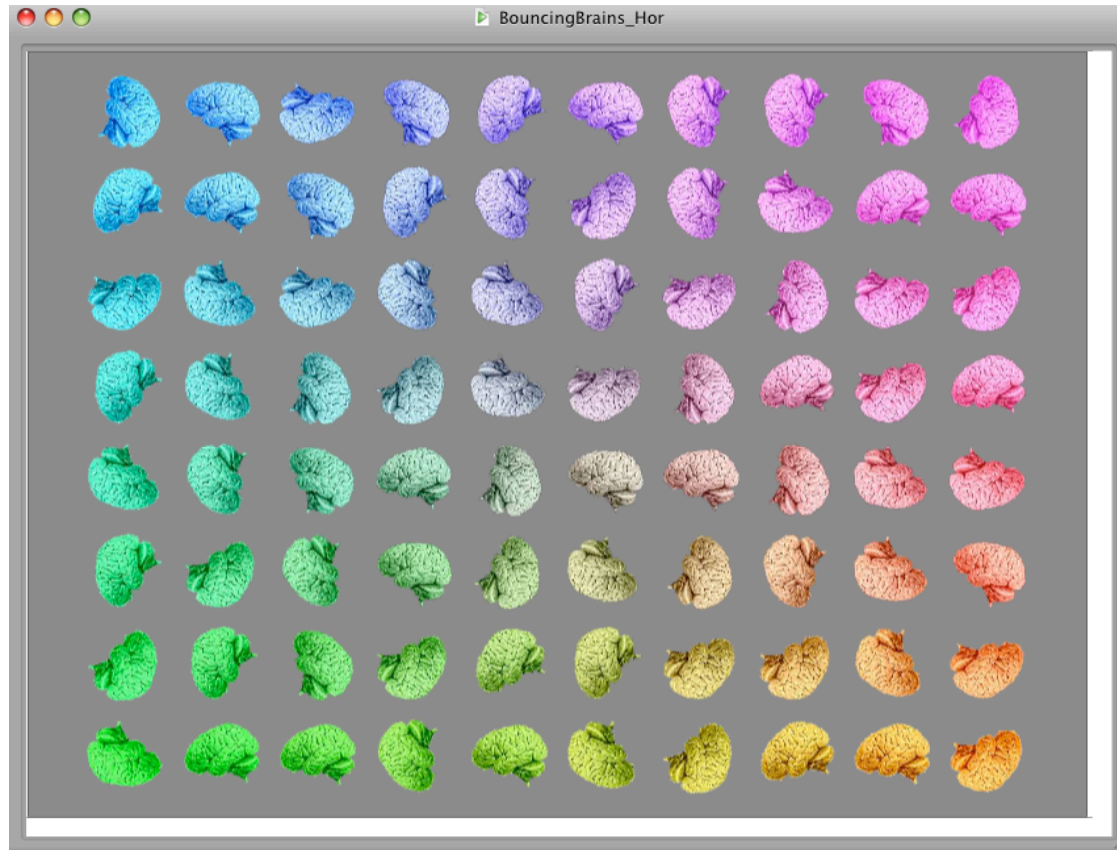

Thorsten Hansen, Kai Hamburger, & Karl R. Gegenfurtner; 2007

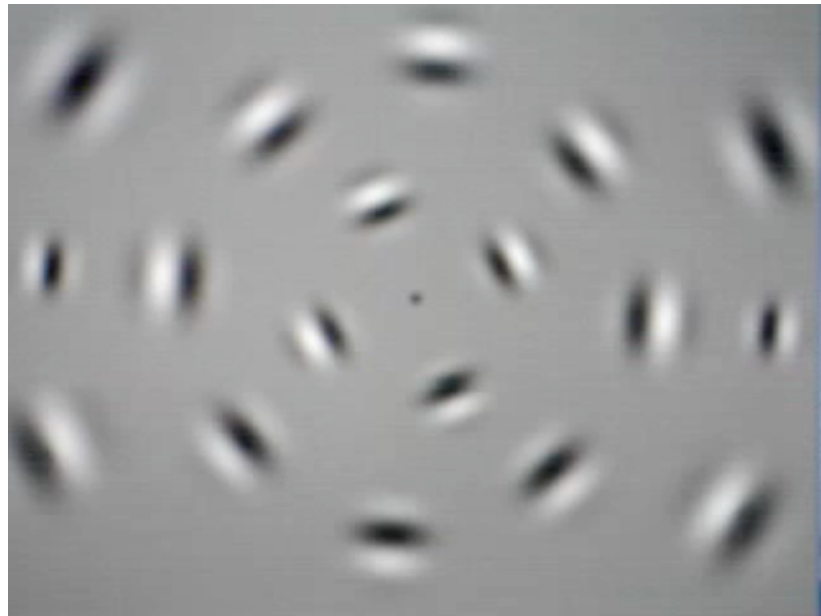
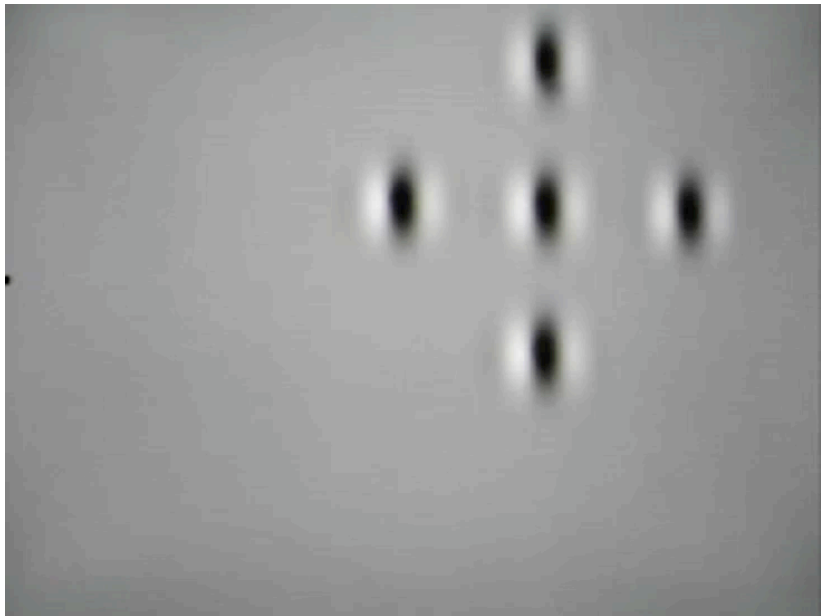

Peter Tse; 2006





Nachbilder von Bewegung (motion after-effects)



- Schauen Sie während der Animation immer genau auf die Mitte der rotierenden Kreise!
- Nach ca. 20 Sekunden können Sie irgend woanders hinsehen ...

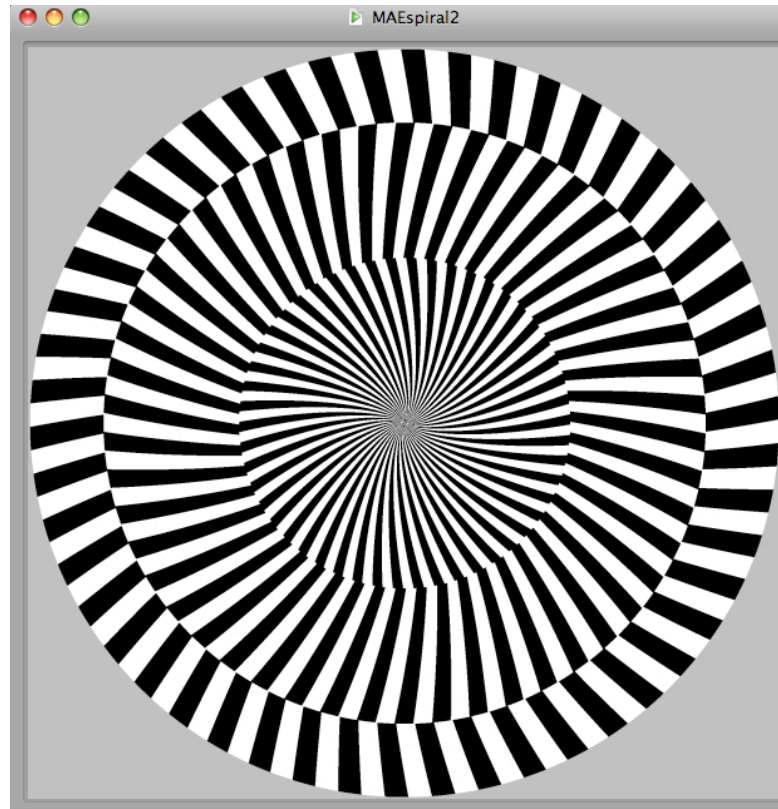



Ambiguities

- Der Necker-Cube:

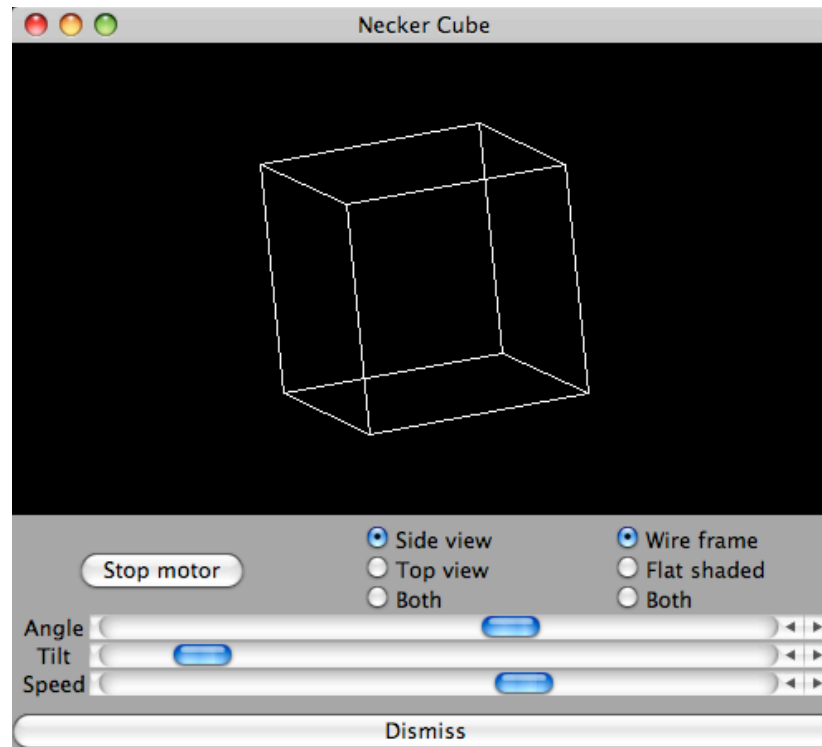

In welcher Richtung dreht sich der Würfel?



Nobuyuki Kayahara

<http://www.procreo.jp/labo/silhouette.swf>



- Selbst mit Shading ist das Bild manchmal nicht eindeutig:



<http://www.kyb.tuebingen.mpg.de/bu/demo/mask/index.html>



Aufmerksamkeit

- Wieviele Fehler enthält die folgende Szene?



[WDR: Quarks & Co, 1. 4. 2008]

- Hintergrund: Zeugenaussagen sind bei der Aufklärung von Verbrechen eine der unverlässlichsten Hilfsmittel!



Nicht-so-Optische Täuschungen

- Ein mathematischer Widerspruch:

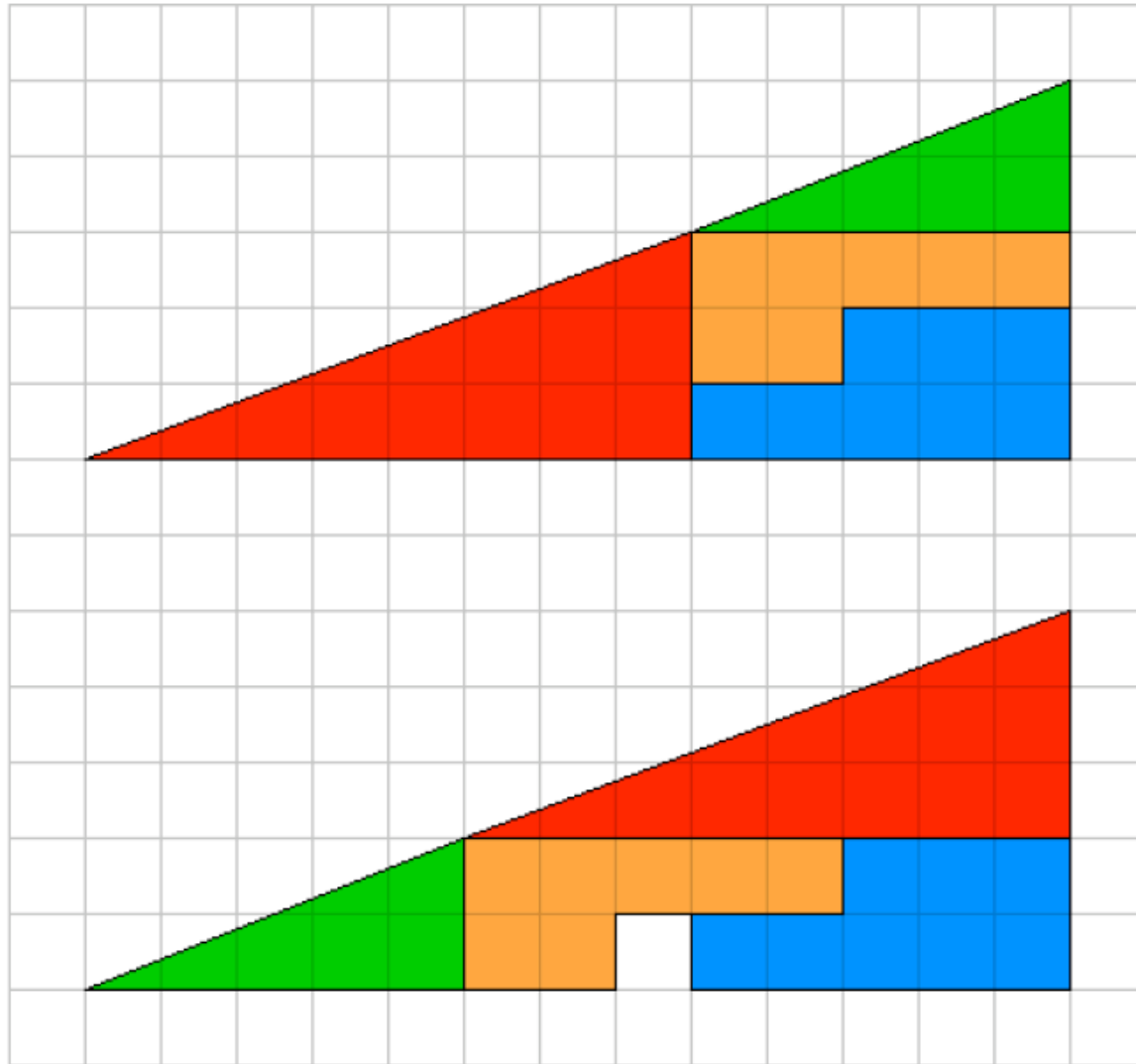
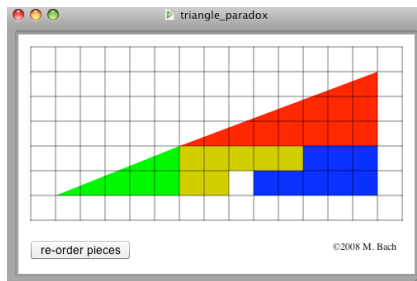



■ Lösung:

Das große Dreieck ist gar kein echtes Dreieck!
Die obere Kante ist an dieser Stelle
leicht nach innen geknickt! ...

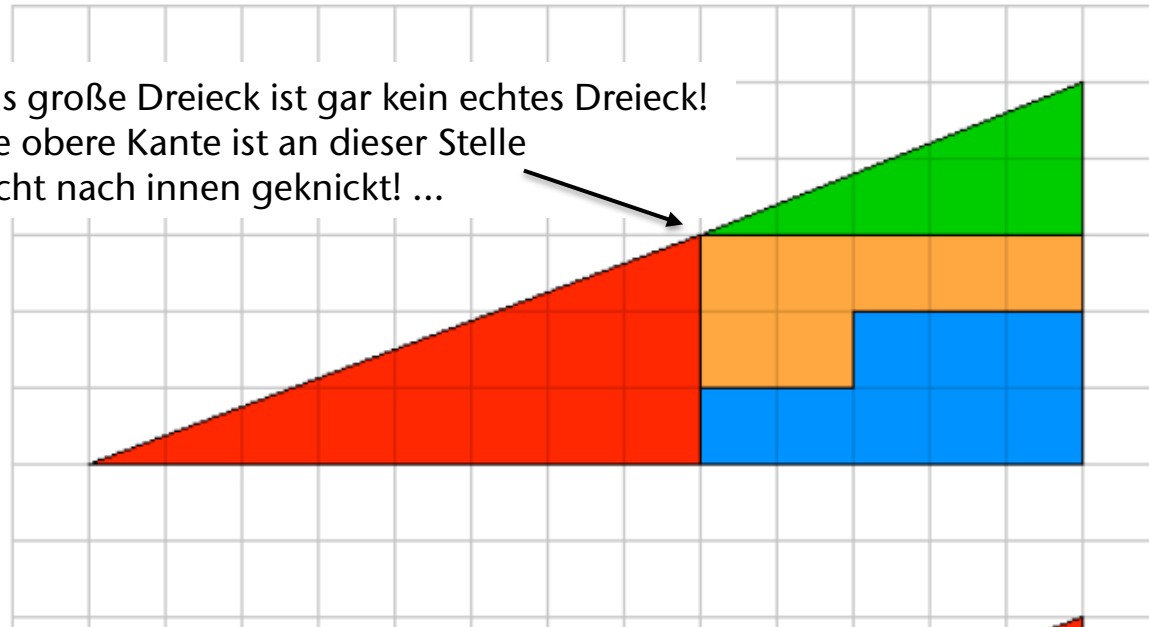

... und an dieser Stelle leicht nach außen.

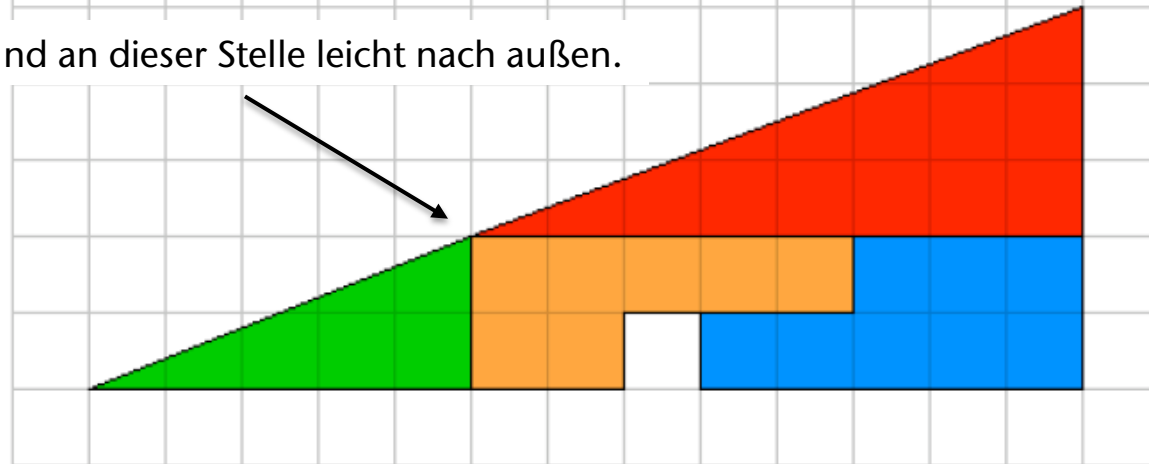



Der blinde Fleck

- Für zu Hause (klappt nur mit dem richtigen Abstand) ...
- Schließen Sie das linke Auge und schauen Sie auf das O. Das X sehen Sie trotzdem noch im Gesichtsfeld.
- Wenn Sie nun den Abstand zum Bildschirm verändern, verschwindet das X bei einem bestimmten Abstand (den Blick nicht vom O nehmen und das X nur "aus dem Augenwinkel" wahrnehmen!).





Discover Your Dominant Eye



1. Select an object that is a few feet away from you.
2. Stare at the object and then point to the object using your index finger.
 - When your eyes are focused on the object and not on your finger, you will see two blurry fingers in your line of sight.
3. Now, close one eye and then close the other eye.
 - You will notice that with one of your eyes closed, your index finger will point exactly at the object; however, when the other eye is closed, your finger will point at an area slightly shifted to the side of the object.
4. The eye with which you see your index finger pointing exactly at the object is your "Dominant Eye."

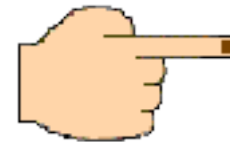



Schattenskulpturen





Akustische Täuschungen (auditory illusions)



- Shepard's Scale:

- Diskret:

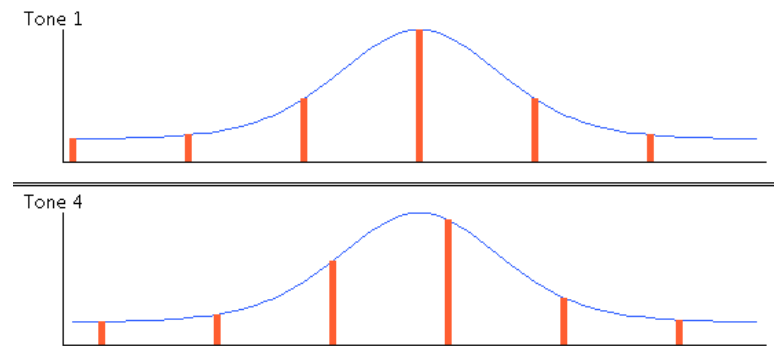

- Kontinuierlich:





Surrealisten



Salvador Dalí



Rene
Magritte



Hans Holbein der Jüngere,
Die franz. Gesandten,
1533.



Arcimboldo,
Sommer,
1527 - 1593



Links, Quellen, etc.

- <http://www.moillusions.com/>
- <http://www.quarks.de>
- <http://www.panoptikum.net/optischetaeuschungen/>
- <http://www.ritsumei.ac.jp/~akitaoka/index-e.html>
- <http://www.michaelbach.de/ot/index.html>
- <http://www.cs.ubc.ca/nest/imager/contributions/flinn/Illusions/Illusions.html>
- <http://illusioncontest.neuralcorrelate.com/> (Best Visual Illusion of the Year Contest)

